



Safety two-hand relay, 24VDC/AC, 2-channel, 2 enabling paths

Part no. ESR5-NZ-21-24VAC-DC
Catalog No. 118703
EL-Nummer (Norway) 4133319

Delivery program

Product range			Electronic safety relays
Basic function			Protective door Two-hand function Feedback circuit
Features			
Mounting width		mm	22.5
Operation			Automatic start External contactor / expansion unit monitoring Two-channel
Supply voltage	U _s		24 V DC 24 V AC, 50/60 Hz
Approval			
Safety related characteristics			EN 574 Typ III C Cat. 4 PL e according to EN ISO 13849-1 SILCL 3 according to IEC 62061 SIL 3 according to IEC 61508
Number of enabling paths to EN 60204-1 Stop functions category			
Enable current paths to IEC/EN 60204-1 Stop category 0			2
Signal current paths			1

Technical data

General

Intended use			Sicherheitsrelais zur Überwachung von Zweihand-Steuerungen nach EN 574 Typ IIIC und Schutztürschaltern. Mit Hilfe dieses Moduls werden Stromkreise sicherheitsgerichtet unterbrochen.
Policies List			EMV 2004/108/EG, Maschinen 2006/42/EG
Standards			EN 574 Part no. IIIC, EN ISO 13849-1:2008, EN 62061:2005+AC:2010, EN 61508, Parts 1-7:2001, EN 50178:1997, EN 60204-1:2006+A1:2009
Dimensions (W x H x D)		mm	22.5 x 114.5 x 99
Mounting width		mm	22.5
Weight		kg	0,19
Mounting position			As required
Mounting			Top-hat rail IEC/EN 60715, 35 mm
Connection type			M3 screw terminals
Lifespan, mechanical	Operations	x 10 ⁶	10
Terminal capacity			
Solid		mm ²	1x (0.2 – 2.5) 2x (0.2 – 1)
Flexible with ferrule		mm ²	1x (0.25 – 2.5) 2x (0.25 – 1)
Solid or stranded		AWG	24 - 12
Terminal screw		Nm	
Pozidriv screwdriver		Size	2
Standard screwdriver		mm	0.6 x 3.5

Max. tightening torque		Nm	0.6
Stripping length		mm	7
Material			Housing: polyamide PA not reinforced Contacts: Material: silver tin oxide, gold plated (AgSnO ₂ , 0.2 μm Au)
Duty factor		% DF	100
Operating conditions			
Climatic environmental conditions			
Climatic proofing			Dry heat to IEC 60068-2-2 Damp heat as per EN 60068-2-3
Ambient temperature			
Operation	θ	°C	-20 - +55
Storage	θ	°C	-40 - +70
Condensation			Non-condensing
Atmospheric conditions			
relative humidity		%	Max. 75
Air pressure (operation)		hPa	795 - 1080
Altitude	Above sea level	m	2000
Power loss	P	W	5.16

Ambient conditions, mechanical

Degree of protection to VDE 0470-1			
Enclosures			IP20
Terminals			IP20
Degree of Protection			Installation location: ≥ IP54
B10d [switching cycles]			300000
Protection against direct contact when actuated from front (EN 50274)			Finger and back-of-hand proof
Vibrations (IEC/EN 60068-2-6)			10 - 150 Hz Amplitude: 0.15 mm Acceleration: 2 g
Clearance in air and creepage distances			EN 50178, UL 508, CSA C22.2, No. 14-95
Rated impulse withstand voltage	U _{imp}	V AC	6000
Insulation			Basic isolation Safe isolation Reinforced insulation
Overvoltage category/pollution degree			III/2
Stop category	according to EN60204-1		12,1
Technical safety parameters:			
Values according to EN ISO 13849-1			
Performance level	according to EN ISO 13849-1		PL e
Category	according to EN ISO 13849-1		Kat. 4
Safety integrity level claim limit	in accordance with 62061		SILCL 3
Safety integrity level	In accordance with IEC 61508		SIL 3
Probability of failure per hour	PFH _d	x 10 ⁻¹⁰	12.1
Proofest High Demand		Months	240
Lifetime		Months	240
Rated operational voltage	U _e	V AC	230
Rated operational voltage	U _e	V	24 V AC, 24 V DC
Permissible range			0.85 - 1.1 x U _e
Rated insulation voltage	U _i	V AC	250
Quadratic summation current		A ²	72 A ² (I _{TH} ² = I ₁ ² + I ₂ ²)
Inrush current		A	min - max 0.025 - 6
Minimum switching capacity		W	0.4

Control circuit

Power supply circuit			
AC operated 50/60 Hz		W	3
DC operated		W	1.5
Fuse for control circuit supply			
24 V			short-circuit proof

Input data

Rated current		mA	S11, S21:60, Y2:45
Current consumption		mA	AC: 125 DC: 60
Voltage at input, starting and feedback circuit		V DC	Approx. 24
Max. resistive load of the cable	R	Ω	≤ 22
Short-circuit current		A	2.3
Pick-up time (K1, K2) for UN automatic mode, typical	t_A	ms	50
Pick-up time (K1, K2) for UN manual operation, typical	t_A	ms	50
Pick-up time		ms	at U_e in automatic mode: normally 50 at U_e in manual mode: normally 50
Reset time (K1, K2) for U_N , normally	t_R	ms	20
Recovery time	t_W	ms	Approx. < 1000
Simultaneity for inputs 1/2	t_{sync}	ms	< 500
Maximum permissible total cable resistance (input and starting circuits for UN)	R_L	Ω	50
Maximum switching frequency		Hz	0.5
Status indication		LED	Green

Output data

Contact type			
Non-delayed enable current paths			2
Non-delayed signal current path			1
Switching voltage			min – max 15 - 250 V AC 15 - 250 V DC
Limiting continuous current		A	per N/O: 6 N/C: 6
Short-circuit protection for output circuits, external			Fuse 6 A gL/gG
Output fuse			
NEOZED (N/O)		gL/gG	10
NEOZED (N/C)		gL/gG	6
Maximum breaking power			
Resistive load ($\tau = 0$ ms)			
24 V DC		W	144
48 V DC		W	288
110 V DC		W	110
220 V DC		W	88
250 V AC		VA	1500
Inductive load ($\tau = 40$ ms)			
24 V DC		W	42
48 V DC		W	42
110 V DC		W	42
220 V DC		W	42
Switching capacity			In accordance with IEC 60947-5-1
AC-15			
230 V		A	5 A bei 3600S/h
DC-13			
24 V		A	5 A bei 3600S/h
Further information (flip catalog)			description

Electromagnetic compatibility (EMC)

Emitted interference			In accordance with EN 61000-6-4
Interference immunity			according to EN 61000-6-2

Design verification as per IEC/EN 61439

Technical data for design verification			
Rated operational current for specified heat dissipation	I_n	A	0
Heat dissipation per pole, current-dependent	P_{vid}	W	0
Equipment heat dissipation, current-dependent	P_{vid}	W	0
Static heat dissipation, non-current-dependent	P_{vs}	W	5.16
Heat dissipation capacity	P_{diss}	W	0
Operating ambient temperature min.		°C	-20
Operating ambient temperature max.		°C	55
IEC/EN 61439 design verification			
10.2 Strength of materials and parts			
10.2.2 Corrosion resistance			
			Meets the product standard's requirements.
10.2.3.1 Verification of thermal stability of enclosures			
			Meets the product standard's requirements.
10.2.3.2 Verification of resistance of insulating materials to normal heat			
			Meets the product standard's requirements.
10.2.3.3 Verification of resistance of insulating materials to abnormal heat and fire due to internal electric effects			
			Meets the product standard's requirements.
10.2.4 Resistance to ultra-violet (UV) radiation			
			Meets the product standard's requirements.
10.2.5 Lifting			
			Does not apply, since the entire switchgear needs to be evaluated.
10.2.6 Mechanical impact			
			Does not apply, since the entire switchgear needs to be evaluated.
10.2.7 Inscriptions			
			Meets the product standard's requirements.
10.3 Degree of protection of ASSEMBLIES			
			Meets the product standard's requirements.
10.4 Clearances and creepage distances			
			Meets the product standard's requirements.
10.5 Protection against electric shock			
			Does not apply, since the entire switchgear needs to be evaluated.
10.6 Incorporation of switching devices and components			
			Does not apply, since the entire switchgear needs to be evaluated.
10.7 Internal electrical circuits and connections			
			Is the panel builder's responsibility.
10.8 Connections for external conductors			
			Is the panel builder's responsibility.
10.9 Insulation properties			
10.9.2 Power-frequency electric strength			
			Is the panel builder's responsibility.
10.9.3 Impulse withstand voltage			
			Is the panel builder's responsibility.
10.9.4 Testing of enclosures made of insulating material			
			Is the panel builder's responsibility.
10.10 Temperature rise			
			The panel builder is responsible for the temperature rise calculation. Eaton will provide heat dissipation data for the devices.
10.11 Short-circuit rating			
			Is the panel builder's responsibility.
10.12 Electromagnetic compatibility			
			Is the panel builder's responsibility.
10.13 Mechanical function			
			The device meets the requirements, provided the information in the instruction leaflet (IL) is observed.

Technical data ETIM 6.0

Relays (EG000019) / Two-hand control relay (EC001452)			
Electric engineering, automation, process control engineering / Low-voltage switch technology / Monitoring equipment (low-voltage switch technology) / Two-hand switchgear (ecl@ss8.1-27-37-18-21 [ACO306008])			
Type of electric connection			-
Rail mounting possible			Yes
Rated control supply voltage U_s at AC 50HZ		V	0 - 0
Rated control supply voltage U_s at AC 60HZ		V	0 - 0
Rated control supply voltage U_s at DC		V	0 - 0
Voltage type for actuating			AC/DC
With detachable clamps			Yes
Type of switch function of the inputs			-
With feedback circuit			Yes
With start input			No
Number of outputs, safety related, undelayed, with contact			2
Number of outputs, safety related, delayed, with contact			0
Number of outputs, safety related, undelayed, semiconductors			0
Number of outputs, safety related, delayed, semiconductors			0
Number of outputs, signalling function, undelayed, with contact			1

Number of outputs, signalling function, delayed, with contact		0
Number of outputs, signalling function, undelayed, semiconductors		0
Number of outputs, signalling function, delayed, semiconductors		0
Suitable for safety functions		Yes
Category according to EN 954-1		4
Type class for safety demands in accordance with EN 574		Type III C
SIL according to IEC 61508		3
Performance level acc. to EN ISO 13849-1		Level e
With approval for TÜV		Yes
With approval for BG BIA		No
With approval according to UL		Yes
Width	mm	22.5
Height	mm	99
Depth	mm	114.5

Approvals

Product Standards		IEC/EN see Technical Data; UL 508; CSA-C22.2 No. 14-95; CE marking
UL File No.		E29184
UL Category Control No.		NKCR; NKCR7
CSA File No.		UL report applies to both US and Canada
CSA Class No.		3211-83; 3211-03
North America Certification		UL listed, certified by UL for use in Canada
Degree of Protection		IEC: IP20, UL/CSA Type: -

Characteristics

PU05907001Z safety manual

Dimensions

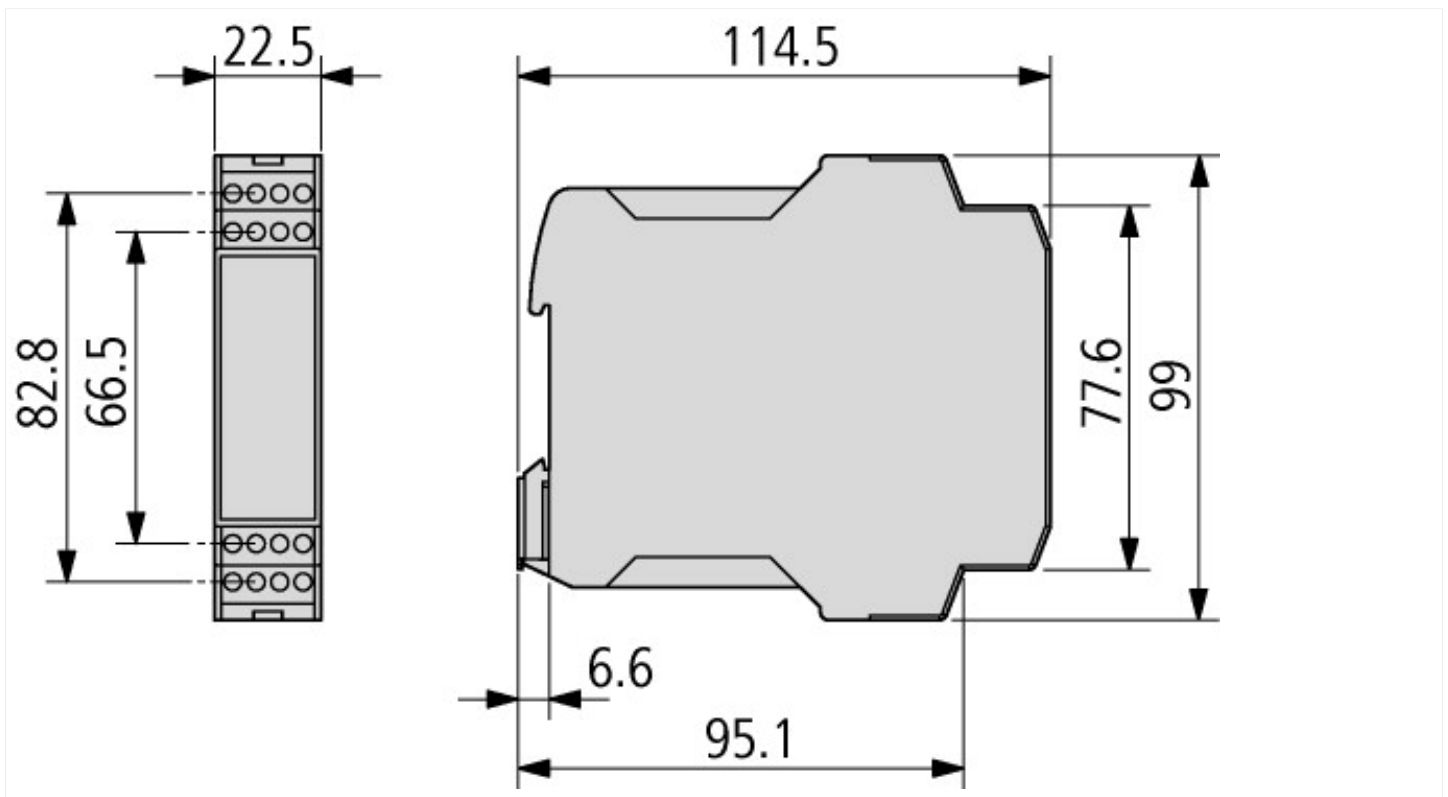

Additional product information (links)

IL05013030Z operator manual for electricians

IL05013030Z operator manual for electricians ftp://ftp.moeller.net/DOCUMENTATION/AWA_INSTRUCTIONS/IL05013030Z2014_04.pdf

description <http://de.ecat.moeller.net/flip-cat/?edition=HPLTE&startpage=13.15>

