



Safety relay emergency stop/protective door, 24V-230VDC/AC, 3 enabling paths



Powering Business Worldwide™

Part no. **ESR5-NO-31-AC-DC**
 Catalog No. **118704**
 Eaton Catalog No. **ESR5-NO-31-AC-DC**
 EL-Nummer **4133321**
 (Norway)

Delivery program

Product range			Electronic safety relays
Basic function			Emergency stop; emergency switching off Protective door Feedback circuit
Features			
Mounting width		mm	45
Operation			Automatic or manual start Start button monitoring
Supply voltage	U _s		single-channel dual-channel
Approval			24 V DC 24 V AC, 50/60 Hz 24 V AC/DC - 230 V AC/DC, 50/60 Hz 115 V AC, 50/60 Hz 230 V AC, 50/60 Hz
Safety related characteristics			 Cat. 4 PL e according to EN ISO 13849-1 SILCL 3 according to IEC 62061 SIL 3 according to IEC 61508
Number of enabling paths to EN 60204-1 Stop functions category			
Enable current paths to IEC/EN 60204-1 Stop category 0			3
Signal current paths			1

Technical data

General

Intended use			Sicherheitsrelais zur Überwachung von Not-Halt- und Schutztürschaltern. Mit Hilfe dieses Modules werden Stromkreise sicherheitsgerichtet unterbrochen.
Policies List			EMV 2004/108/EG, Maschinen 2006/42/EG
Standards			EN ISO 13849-1:2008, EN 62061:2005+AC:2010, EN 61508, Parts 1-7:2001, EN 50178:1997, EN 60204-1:2006+A1:2009
Dimensions (W x H x D)		mm	45 x 114.5 x 99
Mounting width		mm	45
Weight		kg	0,31
Mounting position			As required
Mounting			Top-hat rail IEC/EN 60715, 35 mm
Connection type			M3 screw terminals
Lifespan, mechanical	Operations	x 10 ⁶	10
Terminal capacity			
Solid		mm ²	1x (0.2 – 2.5) 2x (0.2 – 1)
Flexible with ferrule		mm ²	1x (0.25 – 2.5) 2x (0.25 – 1)
Solid or stranded		AWG	24 - 12
Terminal screw		Nm	
Pozidriv screwdriver		Size	2
Standard screwdriver		mm	0.6 x 3.5
Max. tightening torque		Nm	0.6

Stripping length		mm	7
Material			Housing: polyamide PA not reinforced Contacts: Material: silver tin oxide, gold plated (AgSnO ₂ , 0.2 μm Au)
Duty factor		% DF	100
Operating conditions			
Climatic environmental conditions			
Climatic proofing			Dry heat to IEC 60068-2-2 Damp heat as per EN 60068-2-3
Ambient temperature			
Operation	θ	°C	-20 - +55
Storage	θ	°C	-25 - +85
Condensation			Non-condensing
Atmospheric conditions			
relative humidity		%	Max. 75
Air pressure (operation)		hPa	795 - 1080
Altitude	Above sea level	m	2000
Power loss	P	W	4.8

Ambient conditions, mechanical

Degree of protection to VDE 0470-1			
Enclosures			IP20
Terminals			IP20
Degree of Protection			Installation location: ≥ IP54
B10d [switching cycles]			300000
Protection against direct contact when actuated from front (EN 50274)			Finger and back-of-hand proof
Vibrations (IEC/EN 60068-2-6)			10 - 150 Hz Amplitude: 0.15 mm Acceleration: 2 g
Clearance in air and creepage distances			EN 50178, UL 508, CSA C22.2, No. 14-95
Rated impulse withstand voltage	U _{imp}	V AC	4000
Insulation			Basic isolation Safe isolation, reinforced isolation, and 6 kV between input circuit and enable current paths (13-14, 23-24, 33-34) and between (13-14, 23-24, 33-34) with relation to each other.
Overvoltage category/pollution degree			III/2
Stop category	according to EN60204-1		1,26
Technical safety parameters:			
Values according to EN ISO 13849-1			
Performance level	according to EN ISO 13849-1		PL e
Category	according to EN ISO 13849-1		Kat. 4
Safety integrity level claim limit	in accordance with 62061		SILCL 3
Safety integrity level	In accordance with IEC 61508		SIL 3
Probability of failure per hour	PFH _d	x 10 ⁻¹⁰	1.26
Proofest High Demand		Months	240
Proofest Low Demand		Months	59
Rated operational voltage	U _e	V AC	230
Rated operational voltage	U _e	V	24 - 230 V AC, 24 - 230 V DC
Permissible range			0.85 - 1.1 x U _e
Rated insulation voltage	U _i	V AC	250
Quadratic summation current		A ²	50 A ² (I _{TH} ² = I ₁ ² + I ₂ ² + ... + I _N ²)
Inrush current		A	min - max 0.025 - 6
Minimum switching capacity		W	0.4

Control circuit

Power supply circuit			
----------------------	--	--	--

AC operated 50/60 Hz		W	5.8
DC operated		W	2.9
Fuse for control circuit supply			
24 V			short-circuit proof
115 V/230 V			short-circuit proof

Input data

Rated current		mA	S10, S12, S22:35, S34, S35:45
Current consumption		mA	120 V AC: 20 230 V AC: 10 24 V DC: 120
Voltage at input, starting and feedback circuit		V DC	Approx. 24
Max. resistive load of the cable	R	Ω	 11
Short-circuit current		A	0.7
Pick-up time (K1, K2) for UN automatic mode, typical	t _A	ms	250
Pick-up time (K1, K2) for UN manual operation, typical	t _A	ms	60
Pick-up time		ms	at U _e in automatic mode: normally 250 at U _e in manual mode: normally 60
Reset time (K1, K2) for U _N , normally	t _R	ms	20 (when actuated via S11/12 and S21/S22) 500 (on actuation via A1) 50 (at 24 V DC) 110 (at 120 V AC) 280 (at 230 V AC)
Recovery time	t _W	ms	Approx. 1000
Simultaneity for inputs 1/2	t _{sync}	ms	∞
Maximum permissible total cable resistance (input and starting circuits for UN)	R _L	Ω	11
Maximum switching frequency		Hz	0.5
Status indication		LED	Green

Output data

Contact type			
Non-delayed enable current paths			3
Delayed signal current path			1
Switching voltage			min – max 15 - 250 V AC 15 - 250 V DC
Limiting continuous current		A	per N/O: 6 N/C: 6
Short-circuit protection for output circuits, external			Fuse 6 A gL/gG
Output fuse			
NEOZED (N/O)		gL/gG	6
NEOZED (N/C)		gL/gG	6
Maximum breaking power			
Resistive load ($\tau = 0$ ms)			
24 V DC		W	144
48 V DC		W	384
110 V DC		W	80
220 V DC		W	66
250 V AC		VA	2000
Inductive load ($\tau = 40$ ms)			
24 V DC		W	48
48 V DC		W	48
110 V DC		W	48
220 V DC		W	48
Switching capacity			
			In accordance with IEC 60947-5-1
AC-15			
230 V		A	3 A bei 3600S/h
DC-13			
24 V		A	3 A bei 3600S/h
Further information (flip catalog)			description

Electromagnetic compatibility (EMC)

Emitted interference			In accordance with EN 61000-6-4
Interference immunity			according to EN 61000-6-2

Design verification as per IEC/EN 61439

Technical data for design verification			
Rated operational current for specified heat dissipation	I_n	A	0
Heat dissipation per pole, current-dependent	P_{vid}	W	0
Equipment heat dissipation, current-dependent	P_{vid}	W	0
Static heat dissipation, non-current-dependent	P_{vs}	W	4.8
Heat dissipation capacity	P_{diss}	W	0
Operating ambient temperature min.		°C	-20
Operating ambient temperature max.		°C	55
IEC/EN 61439 design verification			
10.2 Strength of materials and parts			
10.2.2 Corrosion resistance			
10.2.2.1 Verification of thermal stability of enclosures			Meets the product standard's requirements.
10.2.2.2 Verification of resistance of insulating materials to normal heat			Meets the product standard's requirements.
10.2.2.3 Verification of resistance of insulating materials to abnormal heat and fire due to internal electric effects			Meets the product standard's requirements.
10.2.4 Resistance to ultra-violet (UV) radiation			
10.2.5 Lifting			Does not apply, since the entire switchgear needs to be evaluated.
10.2.6 Mechanical impact			Does not apply, since the entire switchgear needs to be evaluated.
10.2.7 Inscriptions			
10.3 Degree of protection of ASSEMBLIES			
10.4 Clearances and creepage distances			
10.5 Protection against electric shock			
10.6 Incorporation of switching devices and components			Does not apply, since the entire switchgear needs to be evaluated.
10.7 Internal electrical circuits and connections			
10.8 Connections for external conductors			Is the panel builder's responsibility.
10.9 Insulation properties			
10.9.2 Power-frequency electric strength			Is the panel builder's responsibility.
10.9.3 Impulse withstand voltage			Is the panel builder's responsibility.
10.9.4 Testing of enclosures made of insulating material			Is the panel builder's responsibility.
10.10 Temperature rise			
10.11 Short-circuit rating			Is the panel builder's responsibility.
10.12 Electromagnetic compatibility			Is the panel builder's responsibility.
10.13 Mechanical function			The device meets the requirements, provided the information in the instruction leaflet (IL) is observed.

Technical data ETIM 6.0

Relays (EG000019) / Device for monitoring of safety-related circuits (EC001449)			
Electric engineering, automation, process control engineering / Low-voltage switch technology / Monitoring equipment (low-voltage switch technology) / Device for monitoring of safety-related circuits (ecl@ss8.1-27-37-18-19 [AC0304008])			
Model			Basic device
Suitable for monitoring of position switches			Yes
Suitable for monitoring of emergency-stop circuits			Yes
Suitable for monitoring of valves			No
Suitable for monitoring of optoelectronic protection equipment			No
Suitable for monitoring of tactile sensors			No
Suitable for monitoring of magnetic switches			No
Suitable for monitoring of proximity switches			No
Type of electric connection			Screw connection
Rail mounting possible			Yes
Rated control supply voltage U_s at AC 50HZ		V	0 - 26.4
Rated control supply voltage U_s at AC 60HZ		V	0 - 0

Rated control supply voltage Us at DC	V	0 - 0
Voltage type for actuating		AC/DC
With detachable clamps		Yes
Evaluation inputs		One- and two-channel
With start input		Yes
With muting function		No
With feedback circuit		Yes
Release-delay	s	0 - 0
Number of outputs, safety related, undelayed, with contact		3
Number of outputs, safety related, delayed, with contact		0
Number of outputs, safety related, undelayed, semiconductors		0
Number of outputs, safety related, delayed, semiconductors		0
Number of outputs, signalling function, undelayed, with contact		1
Number of outputs, signalling function, delayed, with contact		0
Number of outputs, signalling function, undelayed, semiconductors		0
Number of outputs, signalling function, delayed, semiconductors		0
Category according to EN 954-1		4
Type of safety acc. IEC 61496-1		-
Stop category acc. to IEC 60204		0
Performance level acc. to EN ISO 13849-1		Level e
SIL according to IEC 61508		3
With approval for TÜV		Yes
With approval for BG BIA		No
With approval according to UL		Yes
Width	mm	45
Height	mm	99
Depth	mm	114.5

Approvals

Product Standards		IEC/EN see Technical Data; UL 508; CSA-C22.2 No. 14-95; CE marking
UL File No.		E29184
UL Category Control No.		NKCR; NKCR7
CSA File No.		UL report applies to both US and Canada
CSA Class No.		3211-83; 3211-03
North America Certification		UL listed, certified by UL for use in Canada
Degree of Protection		IEC: IP20, UL/CSA Type: -

Characteristics

PU05907001Z safety manual

Dimensions

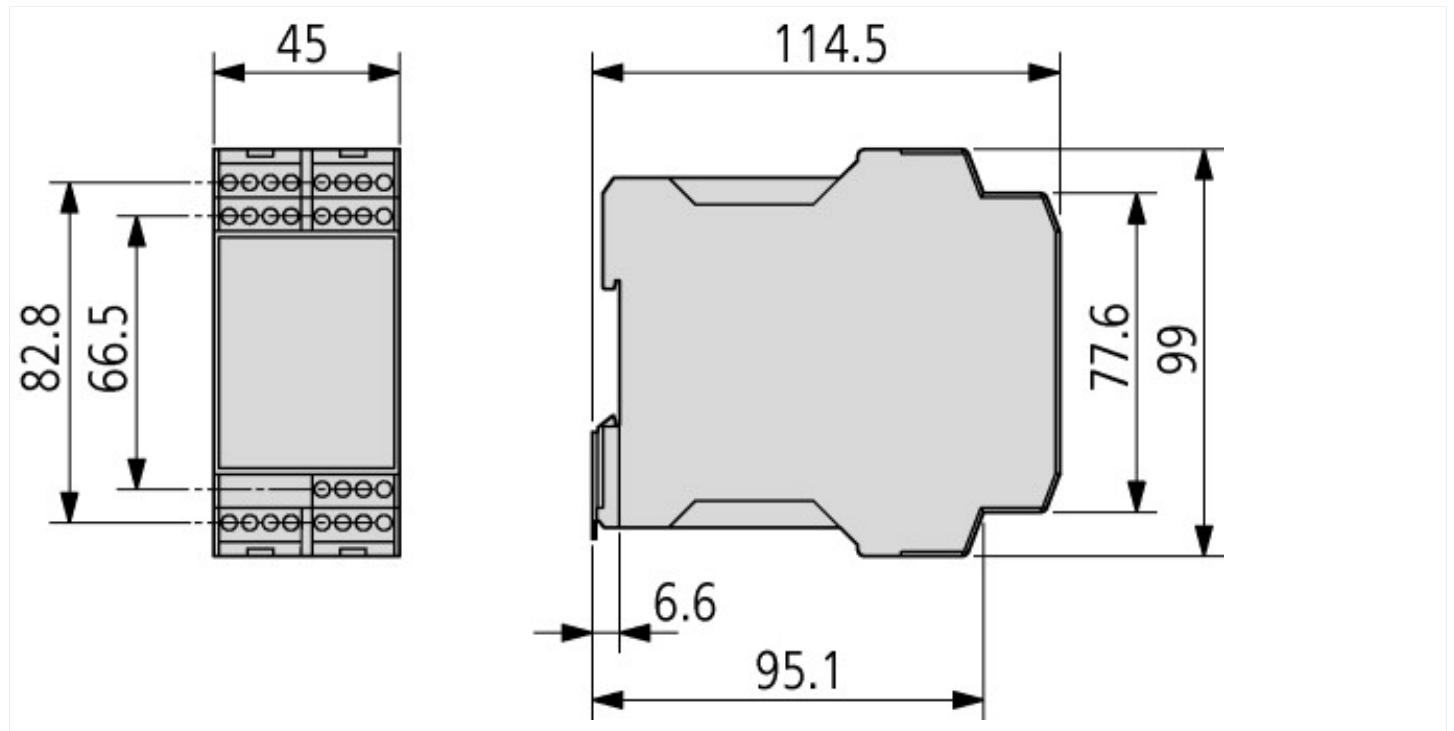

Additional product information (links)

IL05013031Z operator manual for electricians

IL05013031Z operator manual for electricians ftp://ftp.moeller.net/DOCUMENTATION/AWA_INSTRUCTIONS/IL05013031Z2014_04.pdf

description <http://de.ecat.moeller.net/flip-cat/?edition=HPLTE&startpage=13.15>