



**Safety relay emergency stop/protective door/light curtain, 24 V DC, 4 enabling paths(2del.)**

**Part no.** ESR5-NV3-30  
**Catalog No.** 118705  
**EL-Nummer (Norway)** 4133323

**Delivery program**

Product range			Electronic safety relays
Basic function			Emergency stop; emergency switching off Protective door Light curtain Time function Feedback circuit
<b>Features</b>			
Mounting width		mm	22.5
			Automatic or manual start With/without cross-circuit detection
Operation			single-channel dual-channel
Supply voltage	U <sub>s</sub>		24 V DC
Approval			
Safety related characteristics			Cat. 4 PL e according to EN ISO 13849-1 SILCL 3 according to IEC 62061 SIL 3 according to IEC 61508 SIL 3 only for high demand requirements
<b>Number of enabling paths to EN 60204-1 Stop functions category</b>			
Enable current paths to IEC/EN 60204-1 Stop category 0			2
Enable current paths to IEC/EN 60204-1 Stop category 1			2
Signal current paths			0
<b>Instructions</b>			Suitable for safety position switch with mechanical securing action LS-S...MT-ZBZ.

**Technical data**

<b>General</b>			
Intended use			Sicherheitsrelais zur Überwachung von Not-Halt- und Schutztürschaltern. Mit Hilfe dieses Modules werden Stromkreise sicherheitsgerichtet unterbrochen.
Policies List			EMV 2004/108/EG, Maschinen 2006/42/EG
Standards			EN ISO 13849-1:2008, EN 62061:2005+AC:2010, EN 61508, Parts 1-7:2001, EN 50178:1997, EN 60204-1:2006+A1:2009
Dimensions (W x H x D)		mm	22.5 x 114.5 x 99
Mounting width		mm	22.5
Weight		kg	0,20
Mounting position			As required
Mounting			Top-hat rail IEC/EN 60715, 35 mm
Connection type			M3 screw terminals
Lifespan, mechanical	Operations	x 10 <sup>6</sup>	10
Terminal capacity			
Solid		mm <sup>2</sup>	1x (0.2 – 2.5) 2x (0.2 – 1)
Flexible with ferrule		mm <sup>2</sup>	1x (0.25 – 2.5) 2x (0.25 – 1)
Solid or stranded		AWG	24 - 12
Terminal screw		Nm	
Pozidriv screwdriver		Size	2

Standard screwdriver		mm	0.6 x 3.5
Max. tightening torque		Nm	0.6
Stripping length		mm	7
Material			Housing: polyamide PA not reinforced Contacts: Material: silver tin oxide, gold plated (AgSnO <sub>2</sub> , 0.2 μm Au)
Duty factor		% DF	100
Operating conditions			
Climatic environmental conditions			
Climatic proofing			Cold to EN 60068-2-1 Dry heat to IEC 60068-2-2 Damp heat as per EN 60068-2-3
Ambient temperature			
Operation	θ	°C	-20 - +45
Storage	θ	°C	-40 - +70
Condensation			Non-condensing
Atmospheric conditions			
relative humidity		%	Max. 75
Air pressure (operation)		hPa	795 - 1080
Altitude	Above sea level	m	2000
Power loss	P	W	7.8

### Ambient conditions, mechanical

Degree of protection to VDE 0470-1			
Enclosures			IP20
Terminals			IP20
Degree of Protection			Installation location: ≥ IP54
B10d [switching cycles]			400000
Protection against direct contact when actuated from front (EN 50274)			Finger and back-of-hand proof
Vibrations (IEC/EN 60068-2-6)			10 - 150 Hz Amplitude: 0.15 mm Acceleration: 2 g
Clearance in air and creepage distances			DIN EN 60947-1, UL 508, CSA C22.2, No. 14-95
Rated impulse withstand voltage	U <sub>imp</sub>	V AC	4000
Insulation			Basic isolation
Overvoltage category/pollution degree			III/2
Stop category	according to EN60204-1		18
Technical safety parameters:			
Values according to EN ISO 13849-1			
Performance level	according to EN ISO 13849-1		PL e
Category	according to EN ISO 13849-1		Kat. 4
Safety integrity level claim limit	in accordance with 62061		SILCL 3
Safety integrity level	In accordance with IEC 61508		SIL 3
Probability of failure per hour	PFH <sub>d</sub>	x 10 <sup>-10</sup>	18
Proof test High Demand		Months	240
Demand level		Months	< 12
Lifetime		Months	240
Rated operational voltage	U <sub>e</sub>	V AC	230
Rated operational voltage	U <sub>e</sub>	V	24 V DC
Permissible range			0.85 - 1.1 x U <sub>e</sub>
Rated insulation voltage	U <sub>i</sub>	V AC	250
Quadratic summation current		A <sup>2</sup>	55 A <sup>2</sup> (I <sub>TH</sub> <sup>2</sup> = I <sub>1</sub> <sup>2</sup> + I <sub>2</sub> <sup>2</sup> + I <sub>3</sub> <sup>2</sup> + I <sub>4</sub> <sup>2</sup> + I <sub>5</sub> <sup>2</sup> )
Notes			Observe derating curve → Engineering

Inrush current		A	min - max 0.025 - 6
Minimum switching capacity		W	0.4

### Control circuit

Power supply circuit			
DC operated		W	1.8

### Input data

Rated current		mA	S12, S22:3.5, S34, S35:7
Current consumption		mA	DC: 75
Voltage at input, starting and feedback circuit		V DC	Approx. 24
Max. resistive load of the cable	R	$\Omega$	$\leq 500$
Short-circuit current		A	0.1
Pick-up time (K1, K2) for UN automatic mode, typical	$t_A$	ms	150 (controlled start)
Pick-up time (K1, K2) for UN manual operation, typical	$t_A$	ms	150 (controlled start)
Pick-up time		ms	at $U_e$ in automatic mode: normally 150 at $U_e$ in manual mode: normally 150
Reset time (K1, K2) for $U_N$ , normally	$t_R$	ms	20 (non-delayed contacts) 100 (delayed contacts)
OFF-delay	$t_{rz}$	s	0.1 - 30 $\pm$ 40% (K3, K4 adjustable)
Recovery time	$t_W$	ms	Approx. 330 (Wiederanlauf)
Simultaneity for inputs 1/2	$t_{sync}$	ms	$\infty$
Maximum permissible total cable resistance (input and starting circuits for UN)	$R_L$	$\Omega$	500
Maximum switching frequency		Hz	0.5
Status indication		LED	Green

### Output data

Contact type			
Non-delayed enable current paths			2
Delayed enable current paths			2
Switching voltage			min – max 15 - 250 V AC 15 - 250 V DC
Limiting continuous current		A	per N/O: 6 N/C: 6
Short-circuit protection for output circuits, external			Fuse 10 A gL/gG NEOZED
Output fuse			
NEOZED (N/O)		gL/gG	10
NEOZED (N/C)		gL/gG	6
Maximum breaking power			
Resistive load ( $\tau = 0$ ms)			
24 V DC		W	144
48 V DC		W	288
110 V DC		W	90
220 V DC		W	88
250 V AC		VA	1500
Inductive load ( $\tau = 40$ ms)			
24 V DC		W	42
48 V DC		W	33
110 V DC		W	25
220 V DC		W	23
Switching capacity			
			In accordance with IEC 60947-5-1
AC-15			
230 V		A	5 A bei 3600S/h
DC-13			
24 V		A	3 A bei 3600S/h
Further information (flip catalog)			description

### Electromagnetic compatibility (EMC)

Emitted interference			In accordance with EN 61000-6-4
Interference immunity			In accordance with EN 61000-6-2

## Design verification as per IEC/EN 61439

Technical data for design verification			
Rated operational current for specified heat dissipation	$I_n$	A	0
Heat dissipation per pole, current-dependent	$P_{vid}$	W	0
Equipment heat dissipation, current-dependent	$P_{vid}$	W	0
Static heat dissipation, non-current-dependent	$P_{vs}$	W	7.8
Heat dissipation capacity	$P_{diss}$	W	0
Operating ambient temperature min.		°C	-20
Operating ambient temperature max.		°C	45
IEC/EN 61439 design verification			
10.2 Strength of materials and parts			
10.2.2 Corrosion resistance			
			Meets the product standard's requirements.
10.2.3.1 Verification of thermal stability of enclosures			
			Meets the product standard's requirements.
10.2.3.2 Verification of resistance of insulating materials to normal heat			
			Meets the product standard's requirements.
10.2.3.3 Verification of resistance of insulating materials to abnormal heat and fire due to internal electric effects			
			Meets the product standard's requirements.
10.2.4 Resistance to ultra-violet (UV) radiation			
			Meets the product standard's requirements.
10.2.5 Lifting			
			Does not apply, since the entire switchgear needs to be evaluated.
10.2.6 Mechanical impact			
			Does not apply, since the entire switchgear needs to be evaluated.
10.2.7 Inscriptions			
			Meets the product standard's requirements.
10.3 Degree of protection of ASSEMBLIES			
			Meets the product standard's requirements.
10.4 Clearances and creepage distances			
			Meets the product standard's requirements.
10.5 Protection against electric shock			
			Does not apply, since the entire switchgear needs to be evaluated.
10.6 Incorporation of switching devices and components			
			Does not apply, since the entire switchgear needs to be evaluated.
10.7 Internal electrical circuits and connections			
			Is the panel builder's responsibility.
10.8 Connections for external conductors			
			Is the panel builder's responsibility.
10.9 Insulation properties			
10.9.2 Power-frequency electric strength			
			Is the panel builder's responsibility.
10.9.3 Impulse withstand voltage			
			Is the panel builder's responsibility.
10.9.4 Testing of enclosures made of insulating material			
			Is the panel builder's responsibility.
10.10 Temperature rise			
			The panel builder is responsible for the temperature rise calculation. Eaton will provide heat dissipation data for the devices.
10.11 Short-circuit rating			
			Is the panel builder's responsibility.
10.12 Electromagnetic compatibility			
			Is the panel builder's responsibility.
10.13 Mechanical function			
			The device meets the requirements, provided the information in the instruction leaflet (IL) is observed.

## Technical data ETIM 6.0

Relays (EG000019) / Device for monitoring of safety-related circuits (EC001449)			
Electric engineering, automation, process control engineering / Low-voltage switch technology / Monitoring equipment (low-voltage switch technology) / Device for monitoring of safety-related circuits (ec1@ss8.1-27-37-18-19 [AC0304008])			
Model			Basic device
Suitable for monitoring of position switches			Yes
Suitable for monitoring of emergency-stop circuits			Yes
Suitable for monitoring of valves			No
Suitable for monitoring of optoelectronic protection equipment			Yes
Suitable for monitoring of tactile sensors			No
Suitable for monitoring of magnetic switches			No
Suitable for monitoring of proximity switches			No
Type of electric connection			Screw connection
Rail mounting possible			Yes
Rated control supply voltage $U_s$ at AC 50HZ		V	0 - 26.4
Rated control supply voltage $U_s$ at AC 60HZ		V	0 - 0
Rated control supply voltage $U_s$ at DC		V	0 - 0
Voltage type for actuating			DC

With detachable clamps			Yes
Evaluation inputs			One- and two-channel
With start input			Yes
With muting function			No
With feedback circuit			Yes
Release-delay		s	0.1 - 30
Number of outputs, safety related, undelayed, with contact			2
Number of outputs, safety related, delayed, with contact			2
Number of outputs, safety related, undelayed, semiconductors			0
Number of outputs, safety related, delayed, semiconductors			0
Number of outputs, signalling function, undelayed, with contact			0
Number of outputs, signalling function, delayed, with contact			0
Number of outputs, signalling function, undelayed, semiconductors			0
Number of outputs, signalling function, delayed, semiconductors			0
Category according to EN 954-1			4
Type of safety acc. IEC 61496-1			-
Stop category acc. to IEC 60204			1
Performance level acc. to EN ISO 13849-1			Level e
SIL according to IEC 61508			3
With approval for TÜV			Yes
With approval for BG BIA			No
With approval according to UL			Yes
Width		mm	22.5
Height		mm	99
Depth		mm	114.5

## Approvals

Product Standards			IEC/EN see Technical Data; UL 508; CSA-C22.2 No. 14-95; CE marking
UL File No.			E29184
UL Category Control No.			NKCR; NKCR7
CSA File No.			UL report applies to both US and Canada
CSA Class No.			3211-83; 3211-03
North America Certification			UL listed, certified by UL for use in Canada
Degree of Protection			IEC: IP20, UL/CSA Type: -

## Characteristics

PU05907001Z safety manual			
Characteristic curves			



Derating curve

## Dimensions

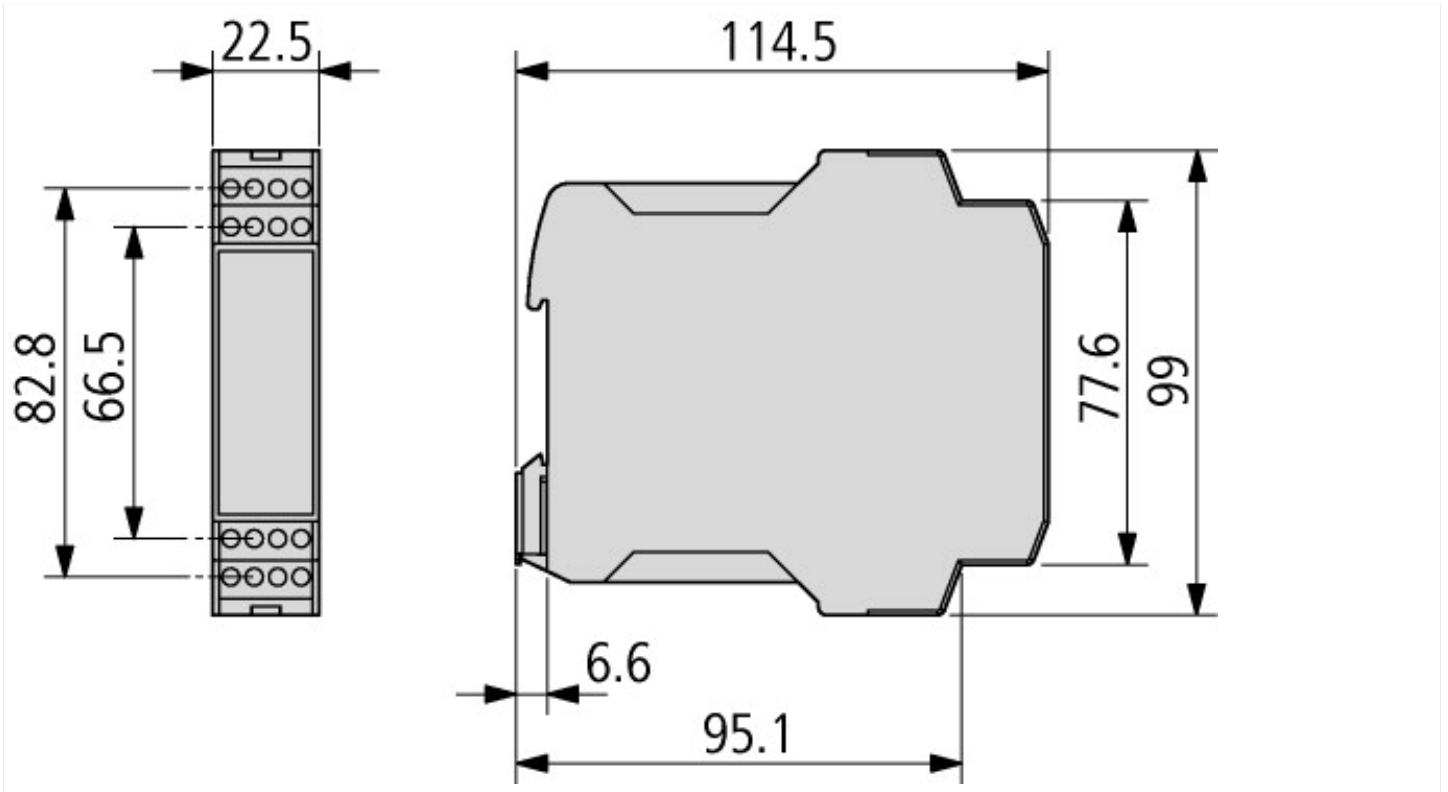

## Additional product information (links)

IL05013033Z operator manual for electricians

IL05013033Z operator manual for electricians [ftp://ftp.moeller.net/DOCUMENTATION/AWA\\_INSTRUCTIONS/IL05013033Z2014\\_03.pdf](ftp://ftp.moeller.net/DOCUMENTATION/AWA_INSTRUCTIONS/IL05013033Z2014_03.pdf)

description <http://de.ecat.moeller.net/flip-cat/?edition=HPLTE&startpage=13.15>