



Insulated enclosure, +knockouts, HxWxD=250x187.5x150mm

Part no. CI23E-125
Catalog No. 019570
EL-Nummer (Norway) 4132075

Delivery program

Dimensions	mm	
Product range		Ci insulated enclosures
Basic function		Basic enclosures
Product function		Individual enclosures
Single unit/Complete unit		Single unit
Degree of Protection		IP65
Description		With metric knockouts in all sides of the enclosure Include fixing straps for wall mounting Sealable cover fasteners Full-area knockouts in the sides can be converted to a distribution board enclosure
Colour		RAL 7032, pebble grey (base) transparent, opaque (cover)
Width	mm	187.5
Height	mm	250
Depth	mm	150
Mounting depth with mounting plate	mm	125
Mounting depth for mounting rail 7.5 mm height	mm	117.5
Mounting depth for mounting rail 15 mm height	mm	110
Enclosure depth		
Legend for the graphic		Dimensions from top: Mounting depth with mounting plate Mounting depth for mounting rail 7.5 mm height Mounting depth for mounting rail 15 mm height Enclosure depth
Enclosure depth	mm	
Type cover		Transparent
Model base		knockout
For use with		PKZM0-.../S(E)00 +NHI or NHI...S +NHI-E +U or A (undervoltage or shunt release) +R(H) +L-PKZ0 (2 off)
Notes A		

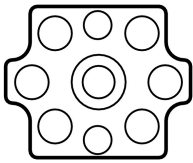

1 x M32/20

6 x M20

2 x M16

B

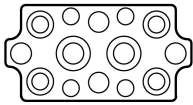

2 x M32/20

4 x M25/16

4 x M20

4 x M16

Technical data

General

Standards			IEC/EN 60529 EN 50262 DIN 43656 DIN 43660 EN 60439-4 for CI...X individual enclosures with combined distribution boards from CI enclosures up to 680 A. Can thus be used for socket combinations and as component for construction site distribution boards.
Climatic proofing			Damp heat, constant, to IEC 60068-2-78 Damp heat, cyclic, to IEC 60068-2-30
Ambient temperature		°C	-40 - +80
Degree of Protection			IP65
Power loss			
Max. radiated heat dissipation with separate mounting, ambient air temperature +20 °C		W	33
Max. radiated heat dissipation in distribution board combination to VDE 0660 Part 500		W	25
Notes			When calculating the heat dissipation, the quadratic relationship of current with the rated diversity factor a must be considered. $P_V = I_2 \times R$ $P_V' = P_V \times a^2$ If no data is available concerning the load relationships of the individual circuits, the rated diversity factor is selected conform to VDE 0660 Part 500.
additional technical data for UL-/CSA- approved devices			see UL-report File No. E54120
Operating and ambient conditions to VDE 0660 Part 500			
Colour			
Base			RAL 7032, pebble grey
Housing body			Transparent, colourless or RAL 7032, pebble grey

Material characteristics

Material			glass-fibre reinforced polycarbonate (base) non-reinforced polycarbonate (cover) Halogen free
Surface treatment			Resistant to corrosion
Colour			RAL 7032, pebble grey (base) transparent, opaque (cover)
Colour			
Base			RAL 7032, pebble grey
Housing body			Transparent, colourless or RAL 7032, pebble grey

Material properties

Electrical			
Track resistance			KB160, KC175 (base, to IEC 60112) KB100, KC200 (cover, to IEC 60112)
Surface resistance to IEC 60093		$\Omega \times 10^{13}$	1
Dielectric strength to IEC 60243-1		kV/mm	30
Thermal			
Temperature resistant			-40 °C - 120 °C (enclosure)

			85 °C (enclosure bolt) 80 °C (gasket)
Mechanical			
Impact resistance			IK10 according to EN 50102
Loading capacity		kg/m ²	5
Chemical resistance			
Chemical resistant			Resistant against: Acids < 10 %, mineral oil, alcohol, gasoline, greases, salt solutions Partly resistant to: Acids > 10 % Not resistant to: alkalis, benzene
Atmospheric			
Saline spray			IEC 60068-2-11
UV resistance			Beneath protective shield
Water consumption to DIN EN ISO 62		%	0.29
Flammability characteristics			
Flammability classification according to UL94			V1 (base) V2 (cover)

Design verification as per IEC/EN 61439

Technical data for design verification			
Heat dissipation, at an ambient temperature of 35°C, delta T: 20 degrees, calculated as per IEC 60890			
Individual enclosure for wall mounting	P _V	CO	12
Starting enclosure for wall mounting	P _V	CO	11
Middle enclosure for wall mounting	P _V	CO	10
Heat dissipation, at an ambient temperature of 35°C, delta T: 35 degrees, calculated as per IEC 60890			
Individual enclosure for wall mounting	P _V	CO	24
Starting enclosure for wall mounting	P _V	CO	22
Middle enclosure for wall mounting	P _V	CO	20
IEC/EN 61439 design verification			
10.2 Strength of materials and parts			
10.2.2 Corrosion resistance			Meets the product standard's requirements.
10.2.3.1 Verification of thermal stability of enclosures			Meets the product standard's requirements.
10.2.3.2 Verification of resistance of insulating materials to normal heat			Meets the product standard's requirements.
10.2.3.3 Verification of resistance of insulating materials to abnormal heat and fire due to internal electric effects			Lower part: 960 °C / cover: 850 °C; meets the product standard's requirements.
10.2.4 Resistance to ultra-violet (UV) radiation			Not relevant to indoor installations.
10.2.5 Lifting			5 kg per enclosure with support frame and lifting aid met; assembled and secured as per the latest applicable instruction leaflet.
10.2.6 Mechanical impact			IK10
10.2.7 Inscriptions			Meets the product standard's requirements.
10.3 Degree of protection of ASSEMBLIES			IP65
10.4 Clearances and creepage distances			Is the panel builder's responsibility.
10.5 Protection against electric shock			Protection class 2, therefore not applicable.
10.6 Incorporation of switching devices and components			Is the panel builder's responsibility.
10.7 Internal electrical circuits and connections			Is the panel builder's responsibility.
10.8 Connections for external conductors			Is the panel builder's responsibility.
10.9 Insulation properties			
10.9.2 Power-frequency electric strength			U _i = 1000 V AC
10.9.3 Impulse withstand voltage			8 kV
10.9.4 Testing of enclosures made of insulating material			Meets the product standard's requirements.
10.10 Temperature rise			The panel builder is responsible for the temperature rise calculation. Eaton will provide heat dissipation data for the devices.
10.11 Short-circuit rating			Is the panel builder's responsibility.
10.12 Electromagnetic compatibility			Is the panel builder's responsibility.
10.13 Mechanical function			Meets the product standard's requirements.

Dimensions

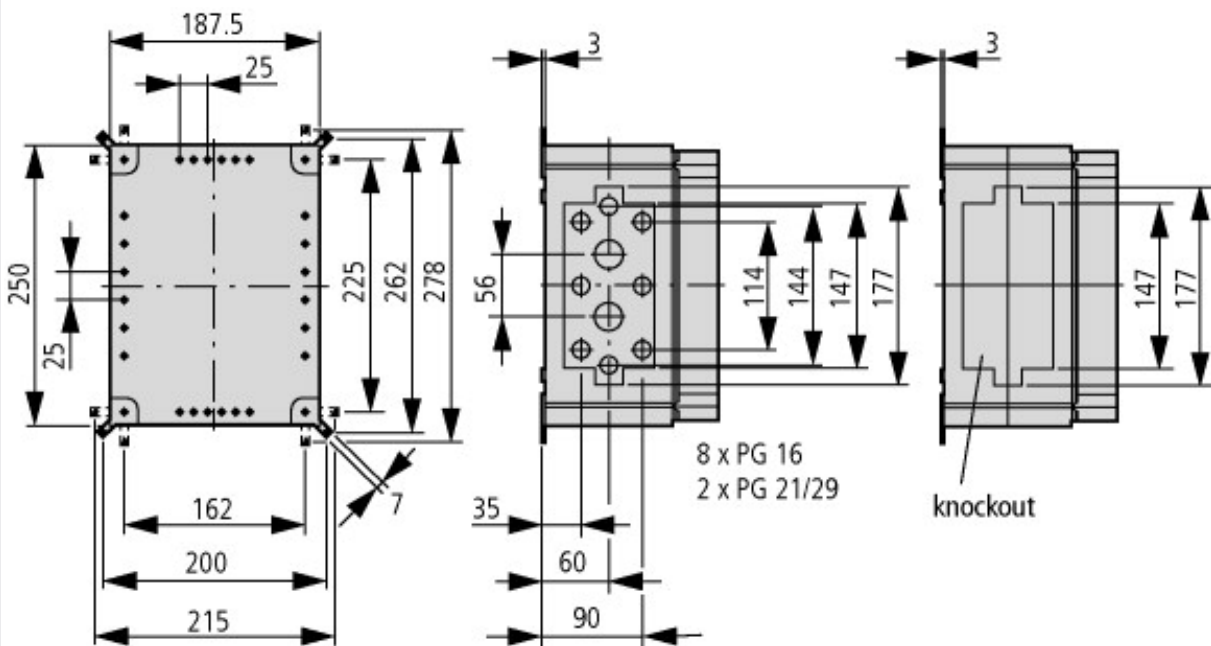
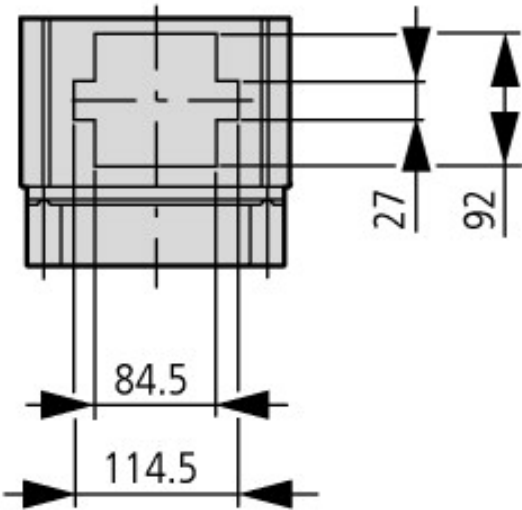
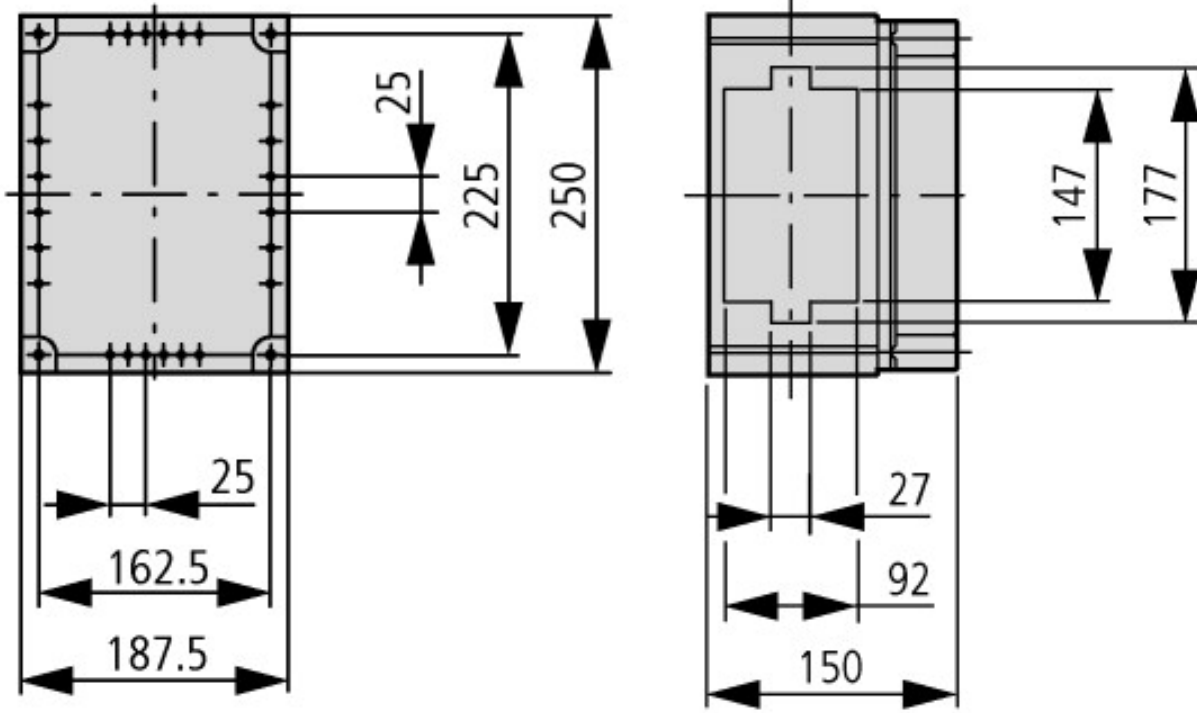

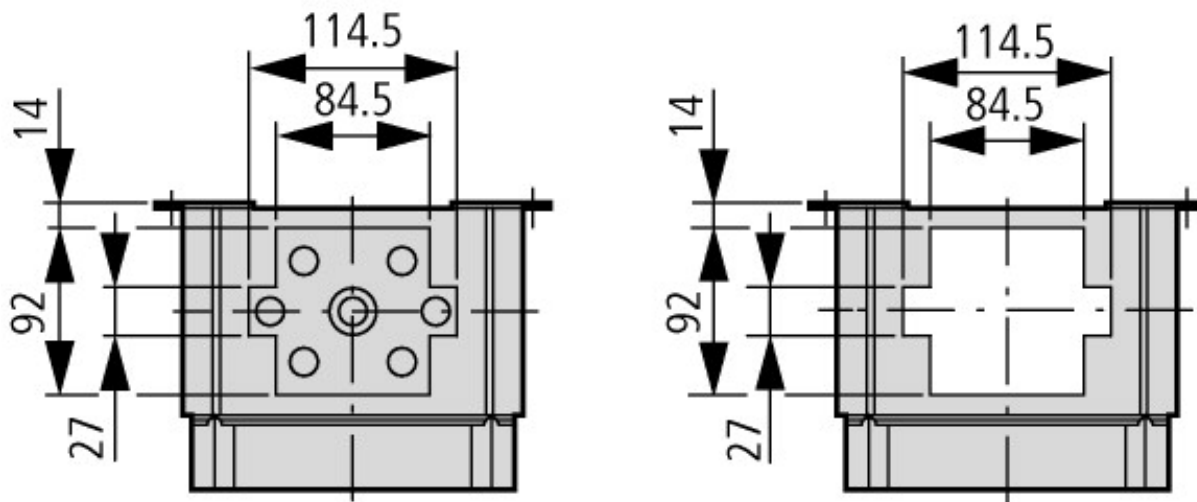

6 × PG 16
1 × PG 21/29

CI23E

Additional product information (links)

Manufacturer's Declaration CI-RoHS	ftp://ftp.moeller.net/DOCUMENTATION/PDF/2013-01-31_Ci_RoHS.pdf
Declaration of conformity	ftp://ftp.moeller.net/DOCUMENTATION/PDF/ci_ce.pdf
Motor starters and "Special Purpose Ratings" for the North American market	http://www.moeller.net/binary/ver_techpapers/ver953en.pdf
Busbar Component Adapters for modern Industrial control panels	http://www.moeller.net/binary/ver_techpapers/ver960en.pdf