



## Sealable shroud

**Part no.** M22-PL-PV  
**Catalog No.** 216397  
**Eaton Catalog No.** M22-PL-PVQ  
**EL-Nummer (Norway)** 4355416



Powering Business Worldwide™

## Delivery program

Product range			Accessories
Part group reference (e.g. DIL)			M22
Basic function accessories			Sealable shroud
Single unit/Complete unit			Single unit
			For devices with mushroom diameter 38 mm transparent with collapse point, can be reused after Emergency-Stop, Emergency switching off operation. with grid 30 x 50 mm the drilling dimensions can be closed with M22(S)-B blanking plug
Degree of Protection			IP65
Connection to SmartWire-DT			no

## Technical data

### General

Degree of Protection			IP65
Ambient temperature			
Open		°C	-25 - +70

## Design verification as per IEC/EN 61439

Technical data for design verification			
Rated operational current for specified heat dissipation	$I_n$	A	0
Heat dissipation per pole, current-dependent	$P_{vid}$	W	0
Equipment heat dissipation, current-dependent	$P_{vid}$	W	0
Static heat dissipation, non-current-dependent	$P_{vs}$	W	0
Heat dissipation capacity	$P_{diss}$	W	0
Operating ambient temperature min.		°C	-25
Operating ambient temperature max.		°C	70
IEC/EN 61439 design verification			
10.2 Strength of materials and parts			
10.2.2 Corrosion resistance			Meets the product standard's requirements.
10.2.3.1 Verification of thermal stability of enclosures			
10.2.3.2 Verification of resistance of insulating materials to normal heat			Meets the product standard's requirements.
10.2.3.3 Verification of resistance of insulating materials to abnormal heat and fire due to internal electric effects			Meets the product standard's requirements.
10.2.4 Resistance to ultra-violet (UV) radiation			Please enquire
10.2.5 Lifting			Does not apply, since the entire switchgear needs to be evaluated.
10.2.6 Mechanical impact			Does not apply, since the entire switchgear needs to be evaluated.
10.2.7 Inscriptions			Meets the product standard's requirements.
10.3 Degree of protection of ASSEMBLIES			Does not apply, since the entire switchgear needs to be evaluated.
10.4 Clearances and creepage distances			Meets the product standard's requirements.
10.5 Protection against electric shock			Does not apply, since the entire switchgear needs to be evaluated.
10.6 Incorporation of switching devices and components			Does not apply, since the entire switchgear needs to be evaluated.
10.7 Internal electrical circuits and connections			Is the panel builder's responsibility.
10.8 Connections for external conductors			Is the panel builder's responsibility.
10.9 Insulation properties			
10.9.2 Power-frequency electric strength			Is the panel builder's responsibility.
10.9.3 Impulse withstand voltage			Is the panel builder's responsibility.
10.9.4 Testing of enclosures made of insulating material			Is the panel builder's responsibility.
10.10 Temperature rise			Not applicable.

10.11 Short-circuit rating		Is the panel builder's responsibility. The specifications for the switchgear must be observed.
10.12 Electromagnetic compatibility		Is the panel builder's responsibility. The specifications for the switchgear must be observed.
10.13 Mechanical function		The device meets the requirements, provided the information in the instruction leaflet (IL) is observed.

## Technical data ETIM 6.0

Low-voltage industrial components (EG000017) / Protective cover for control circuit devices (EC002040)		
Electric engineering, automation, process control engineering / Low-voltage switch technology / Low-voltage switch technology (accessories) / Protective cover for command devices (ecI@ss8.1-27-37-92-18 [AC0047008])		
Colour		Transparent
Shape		Round

## Approvals

North America Certification		UL/CSA certification not required
-----------------------------	--	-----------------------------------

## Dimensions

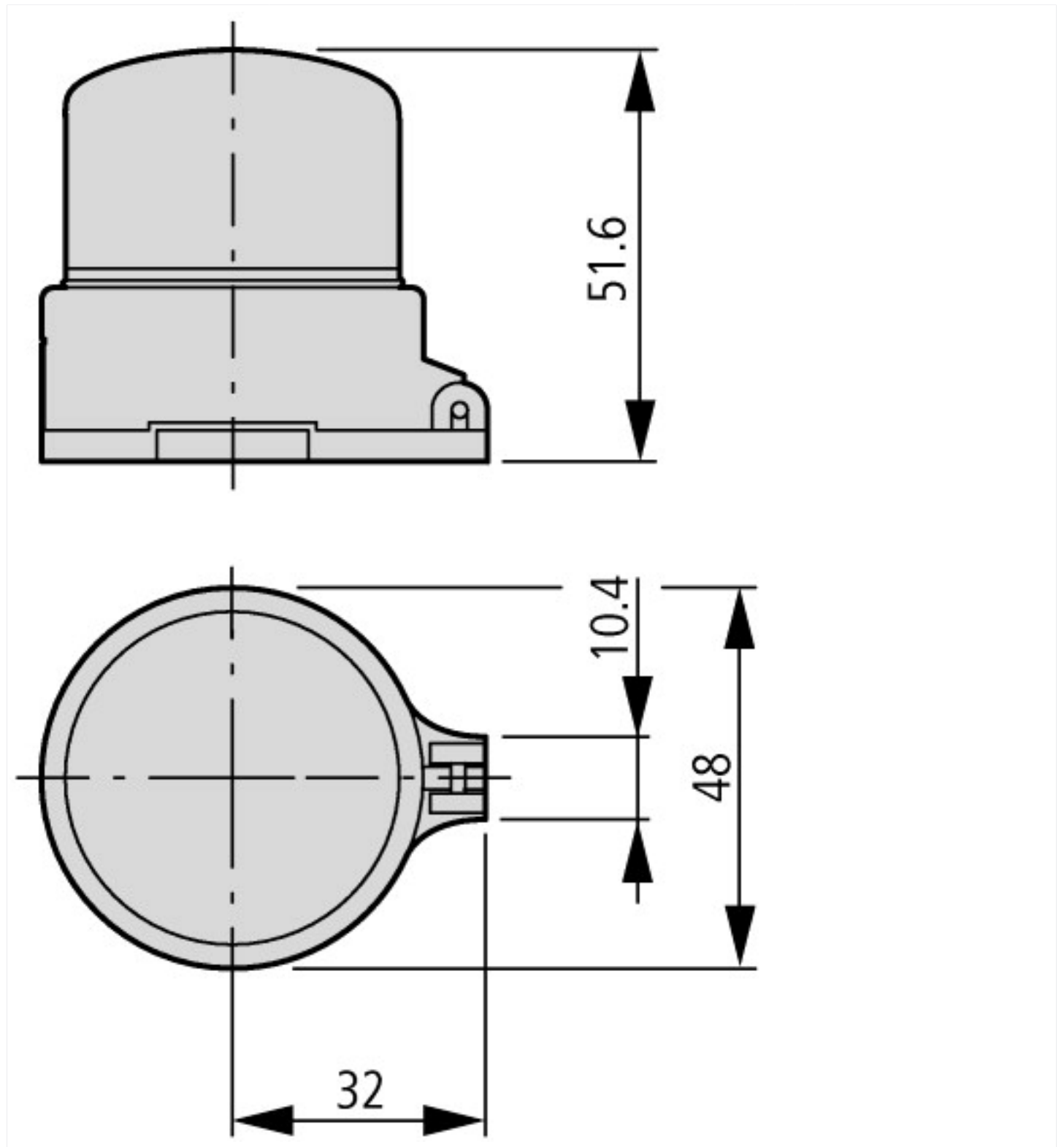

## Additional product information (links)

IL0471600ZZ (AWA1160-1745) RMQ-Titan System

IL0471600ZZ (AWA1160-1745) RMQ-Titan System

[ftp://ftp.moeller.net/DOCUMENTATION/AWA\\_INSTRUCTIONS/IL0471600ZZ2017\\_01.pdf](ftp://ftp.moeller.net/DOCUMENTATION/AWA_INSTRUCTIONS/IL0471600ZZ2017_01.pdf)