



Display, 80mm, 132x64pixels, monochrome, IP65_x, with Eaton logotype

Part no. MFD-80
Catalog No. 265250
EL-Nummer (Norway) 4519700

Delivery program

Product range			Multi-function-display MFD-Titan
Accessories			Remote text display monochrome display 132 × 64 pixels with switchable backlight removable Titan front frame Custom laser inscriptions possible with MFD-COMBINATION (article no. 2010801) product
Display			with display, without keypad
Eaton logotype			with Eaton company logotype
Degree of Protection			IP65

Technical data

General

Standards			EN 61000-6-1/-2/-3/-4, IEC 60068-2-6, IEC 60068-2-27
Dimensions (W x H x D)		mm	86.5 x 86.5 x 21.5 (with actuators) 86.5 x 86.5 x 20 (without actuators)
Weight		kg	0.13
Mounting			2 x 22.5 mm, display fixed with 2 fixing rings. Wall thickness: without top-hat rail (CPU) 1 - 6 mm with top-hat rail 1 - 4 mm
Power loss	P	W	0

Climatic environmental conditions

Operating ambient temperature		°C	-25 to 55, cold as per IEC 60068-2-1, heat as per IEC 60068-2-2
Condensation			Take appropriate measures to prevent condensation
LCD display (clearly legible)		°C	-5 - 50 - (-10 to 0 when background lighting is switched on (continuous operation))
Storage		°C	-40 - 70
Relative humidity, non-condensing (IEC/EN 60068-2-30)		%	5 - 95
Air pressure (operation)		hPa	795 - 1080

Ambient conditions, mechanical

Protection type (IEC/EN 60529, EN50178, VBG 4)			IP65
Vibrations (IEC/EN 60068-2-6)		Hz	
Constant amplitude 0.15 mm		Hz	10 - 57
Constant acceleration 2 g		Hz	57 - 150
Mechanical shock resistance (IEC/EN 60068-2-27) semi-sinusoidal 15 g/11 ms		Impacts	18
Drop to IEC/EN 60068-2-31	Drop height	mm	50
Free fall, packaged (IEC/EN 60068-2-32)		m	1
Mounting position			Vertical or horizontal

Electromagnetic compatibility (EMC)

Electrostatic discharge (IEC/EN 61000-4-2, Level 3, ESD)		kV	
Air discharge		kV	8
Contact discharge		kV	6
Electromagnetic fields (RFI) to IEC EN 61000-4-3		V/m	10
Radio interference suppression			EN 55011 Class B, EN 55022 Class B
Burst Impulse (IEC/EN 61000-4-4, Level 3)			
Supply cable		kV	2
Signal lines		kV	2
Immunity to line-conducted interference to (IEC/EN 61000-4-6)		V	10

Insulation resistance

Clearance in air and creepage distances			EN 50178, UL 508, CSA C22.2, No. 142
Insulation resistance			EN 50178

Design verification as per IEC/EN 61439

Technical data for design verification			
Rated operational current for specified heat dissipation	I_n	A	0
Heat dissipation per pole, current-dependent	P_{vid}	W	0
Equipment heat dissipation, current-dependent	P_{vid}	W	0
Static heat dissipation, non-current-dependent	P_{vs}	W	0
Heat dissipation capacity	P_{diss}	W	0
Operating ambient temperature min.		°C	-25
Operating ambient temperature max.		°C	55
IEC/EN 61439 design verification			
10.2 Strength of materials and parts			
10.2.2 Corrosion resistance			Meets the product standard's requirements.
10.2.3.1 Verification of thermal stability of enclosures			Meets the product standard's requirements.
10.2.3.2 Verification of resistance of insulating materials to normal heat			Meets the product standard's requirements.
10.2.3.3 Verification of resistance of insulating materials to abnormal heat and fire due to internal electric effects			Meets the product standard's requirements.
10.2.4 Resistance to ultra-violet (UV) radiation			Please enquire
10.2.5 Lifting			Does not apply, since the entire switchgear needs to be evaluated.
10.2.6 Mechanical impact			Does not apply, since the entire switchgear needs to be evaluated.
10.2.7 Inscriptions			Meets the product standard's requirements.
10.3 Degree of protection of ASSEMBLIES			Meets the product standard's requirements.
10.4 Clearances and creepage distances			Meets the product standard's requirements.
10.5 Protection against electric shock			Does not apply, since the entire switchgear needs to be evaluated.
10.6 Incorporation of switching devices and components			Does not apply, since the entire switchgear needs to be evaluated.
10.7 Internal electrical circuits and connections			Is the panel builder's responsibility.
10.8 Connections for external conductors			Is the panel builder's responsibility.
10.9 Insulation properties			
10.9.2 Power-frequency electric strength			Is the panel builder's responsibility.
10.9.3 Impulse withstand voltage			Is the panel builder's responsibility.
10.9.4 Testing of enclosures made of insulating material			Is the panel builder's responsibility.
10.10 Temperature rise			The panel builder is responsible for the temperature rise calculation. Eaton will provide heat dissipation data for the devices.
10.11 Short-circuit rating			Is the panel builder's responsibility.
10.12 Electromagnetic compatibility			Is the panel builder's responsibility.
10.13 Mechanical function			The device meets the requirements, provided the information in the instruction leaflet (IL) is observed.

Technical data ETIM 6.0

PLC's (EG000024) / Graphic panel (EC001412)			
Electric engineering, automation, process control engineering / Control / Operate and Observe (HMI) / Graphic panel (HMI) (ecl@ss8.1-27-24-23-02 [BAA722010])			
Supply voltage AC 50 Hz		V	0 - 0
Supply voltage AC 60 Hz		V	0 - 0
Supply voltage DC		V	20.4 - 28.8
Voltage type of supply voltage			DC
Number of HW-interfaces industrial Ethernet			0
Number of HW-interfaces PROFINET			0
Number of HW-interfaces RS-232			0
Number of HW-interfaces RS-422			0
Number of HW-interfaces RS-485			0
Number of HW-interfaces serial TTY			0
Number of HW-interfaces USB			0
Number of HW-interfaces parallel			0
Number of HW-interfaces Wireless			0
Number of HW-interfaces other			1
With SW interfaces			No
Supporting protocol for TCP/IP			No

Supporting protocol for PROFIBUS			No
Supporting protocol for CAN			No
Supporting protocol for INTERBUS			No
Supporting protocol for ASI			No
Supporting protocol for KNX			No
Supporting protocol for MODBUS			No
Supporting protocol for Data-Highway			No
Supporting protocol for DeviceNet			No
Supporting protocol for SUCONET			No
Supporting protocol for LON			No
Supporting protocol for PROFINET IO			No
Supporting protocol for PROFINET CBA			No
Supporting protocol for SERCOS			No
Supporting protocol for Foundation Fieldbus			No
Supporting protocol for EtherNet/IP			No
Supporting protocol for AS-Interface Safety at Work			No
Supporting protocol for DeviceNet Safety			No
Supporting protocol for INTERBUS-Safety			No
Supporting protocol for PROFIsafe			No
Supporting protocol for SafetyBUS p			No
Supporting protocol for other bus systems			Yes
Radio standard Bluetooth			No
Radio standard WLAN 802.11			No
Radio standard GPRS			No
Radio standard GSM			No
Radio standard UMTS			No
IO link master			No
Type of display			LCD
With colour display			No
Number of colours of the display			2
Number of grey-scales/blue-scales of display			2
Screen diagonal		inch	2.75
Number of pixels, horizontal			132
Number of pixels, vertical			64
Useful project memory/user memory		kByte	0
With numeric keyboard			No
With alpha numeric keyboard			No
Number of function buttons, programmable			9
Number of buttons with LED			0
Number of system buttons			0
With touch screen			No
With message indication			Yes
With message system (incl. buffer and confirmation)			No
Process value representation (output) possible			Yes
Process default value (input) possible			Yes
With recipes			No
Number of password levels			0
Printer output available			No
Number of online languages			256
Additional software components, loadable			Yes
Degree of protection (IP), front side			IP65
Operation temperature		°C	-5 - 55
Rail mounting possible			Yes
Wall mounting/direct mounting			No
Suitable for safety functions			No

Width of the front	mm	86.5
Height of the front	mm	86.5
Built-in depth	mm	43

Approvals

Product Standards		IEC/EN see Technical Data; UL 508; CSA C22.2 No. 142-M1987; CSA C22.2 No. 213-M1987; CE marking
UL File No.		E135462
UL Category Control No.		NRAQ
CSA File No.		012528
CSA Class No.		2252-01 + 2258-02
North America Certification		UL listed, CSA certified
Degree of Protection		IEC: IP65, UL/CSA Type 4X

Dimensions

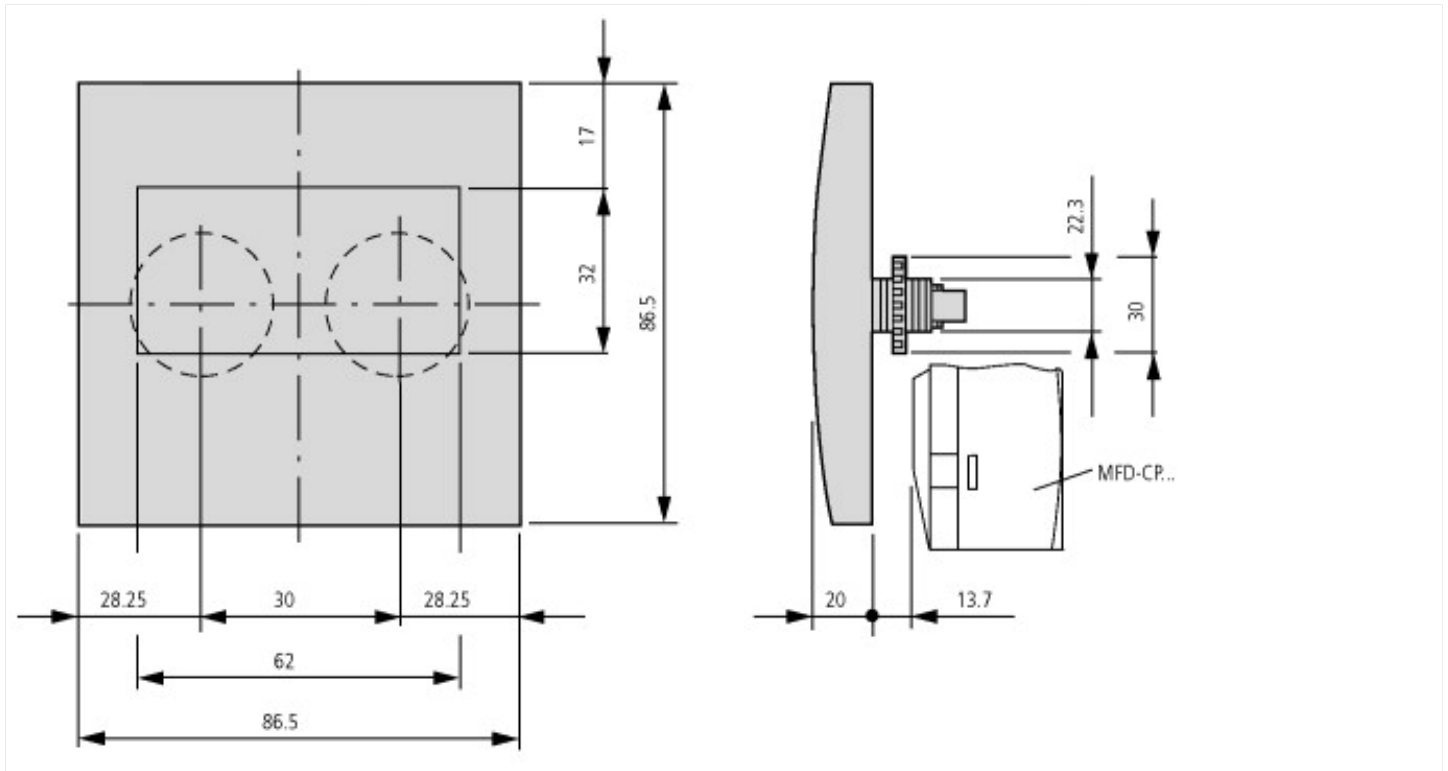

Additional product information (links)

Instruction leaflet "Multi-function display, easy control relays" IL05013014Z (AWA2528-2019)

Instruction leaflet "Multi-function display, easy control relays" IL05013014Z (AWA2528-2019) ftp://ftp.moeller.net/DOCUMENTATION/AWA_INSTRUCTIONS/IL05013014Z2010_11.pdf

Instruction leaflet "protective diaphragm for multi-function display" IL05013017Z (AWA2528-2174)

Instruction leaflet "protective diaphragm for multi-function display" IL05013017Z (AWA2528-2174) ftp://ftp.moeller.net/DOCUMENTATION/AWA_INSTRUCTIONS/IL05013017Z2010_11.pdf

Instruction leaflet "power supply unit, communication"

Instruction leaflet "power supply unit, communication" ftp://ftp.moeller.net/DOCUMENTATION/AWA_INSTRUCTIONS/IL05013018Z.pdf

Manual "MFD-Titan multi-function display" MN05002001Z (AWB2528-1480)

Handbuch Multi-Funktions-Display MFD-Titan MN05002001Z (AWB2528-1480) - Deutsch ftp://ftp.moeller.net/DOCUMENTATION/AWB_MANUALS/MN05002001Z_DE.pdf

Manual "MFD-Titan multi-function display" MN05002001Z (AWB2528-1480) - English ftp://ftp.moeller.net/DOCUMENTATION/AWB_MANUALS/MN05002001Z_EN.pdf

Manual "MFD-CP4, power supply unit/communication module" MN05013011Z (AWB2528-1548)

Handbuch MFD-CP4, Netzteil-Kommunikationsmodul MN05013011Z (AWB2528-1548) - Deutsch ftp://ftp.moeller.net/DOCUMENTATION/AWB_MANUALS/MN05013011Z_DE.pdf

Manual "MFD-CP4, power supply unit/communication module" MN05013011Z (AWB2528-1548) - English ftp://ftp.moeller.net/DOCUMENTATION/AWB_MANUALS/MN05013011Z_EN.pdf

