

Star-delta contactor combination, 132kW/400V/AC3

Part no. SDAINLM260(230V50HZ,240V60HZ)
Catalog No. 101031
Eaton Catalog No. XTSD260G11F

Delivery program

Product range			Contactor combinations
Application			Star-delta motor starting for contactor combinations
Accessories			Star-delta combinations SDAINL
Utilization category			NAC-3: Normal AC induction motors: starting, switch off during running
Notes			Also suitable for motors with efficiency class IE3. IE3-ready devices are identified by the logo on their packaging.
Description			Operating frequency: maximum 30 starts per hour
Rated operational current			
AC-3			
380 V 400 V	I _e	A	260
Max. rating for three-phase motors, 50 - 60 Hz			
AC-3			
220 V 230 V	P	kW	75
380 V 400 V	P	kW	132
500 V	P	kW	160
660 V 690 V	P	kW	160
Max. changeover time		s	20
Actuating voltage			230 V 50 Hz, 240 V 60 Hz
Voltage AC/DC			AC operation
Individual components of the combination			
Mains contactor Q11		Part no.	DILM150 + DILM150-XHI31
Delta contactor Q15		Part no.	DILM150 + DILM150-XHI11
Star contactor Q13		Part no.	DILM95 + DILM150-XHI11
Timing relay K1		Part no.	ETR4-51
Spare auxiliary contacts			

Design verification as per IEC/EN 61439

Technical data for design verification			
Rated operational current for specified heat dissipation	I _n	A	260
Heat dissipation per pole, current-dependent	P _{vid}	W	26.3
Equipment heat dissipation, current-dependent	P _{vid}	W	78.8
Static heat dissipation, non-current-dependent	P _{vs}	W	6.6
Heat dissipation capacity	P _{diss}	W	0
Operating ambient temperature max.		°C	-25
Operating ambient temperature max.		°C	60
IEC/EN 61439 design verification			
10.2 Strength of materials and parts			

10.2.2 Corrosion resistance		Meets the product standard's requirements.
10.2.3.1 Verification of thermal stability of enclosures		Meets the product standard's requirements.
10.2.3.2 Verification of resistance of insulating materials to normal heat		Meets the product standard's requirements.
10.2.3.3 Verification of resistance of insulating materials to abnormal heat and fire due to internal electric effects		Meets the product standard's requirements.
10.2.4 Resistance to ultra-violet (UV) radiation		Meets the product standard's requirements.
10.2.5 Lifting		Does not apply, since the entire switchgear needs to be evaluated.
10.2.6 Mechanical impact		Does not apply, since the entire switchgear needs to be evaluated.
10.2.7 Inscriptions		Meets the product standard's requirements.
10.3 Degree of protection of ASSEMBLIES		Does not apply, since the entire switchgear needs to be evaluated.
10.4 Clearances and creepage distances		Meets the product standard's requirements.
10.5 Protection against electric shock		Does not apply, since the entire switchgear needs to be evaluated.
10.6 Incorporation of switching devices and components		Does not apply, since the entire switchgear needs to be evaluated.
10.7 Internal electrical circuits and connections		Is the panel builder's responsibility.
10.8 Connections for external conductors		Is the panel builder's responsibility.
10.9 Insulation properties		
10.9.2 Power-frequency electric strength		Is the panel builder's responsibility.
10.9.3 Impulse withstand voltage		Is the panel builder's responsibility.
10.9.4 Testing of enclosures made of insulating material		Is the panel builder's responsibility.
10.10 Temperature rise		The panel builder is responsible for the temperature rise calculation. Eaton will provide heat dissipation data for the devices.
10.11 Short-circuit rating		Is the panel builder's responsibility. The specifications for the switchgear must be observed.
10.12 Electromagnetic compatibility		Is the panel builder's responsibility. The specifications for the switchgear must be observed.
10.13 Mechanical function		The device meets the requirements, provided the information in the instruction leaflet (IL) is observed.

Technical data ETIM 6.0

Low-voltage industrial components (EG000017) / Combination of contactors (EC000010)		
Electric engineering, automation, process control engineering / Low-voltage switch technology / Contactor (LV) / Combination of contactor (ecl@ss8.1-27-37-10-09 [AGZ572011])		
Function		Star-delta contactor
Rated control supply voltage U_s at AC 50HZ	V	230 - 230
Rated control supply voltage U_s at AC 60HZ	V	240 - 240
Rated control supply voltage U_s at DC	V	0 - 0
Voltage type for actuating		AC
Rated operation current I_e at AC-3, 400 V	A	260
Rated operation power at AC-3, 400 V	kW	132
Type of electrical connection of main circuit		Screw connection
Degree of protection (IP)		IP00

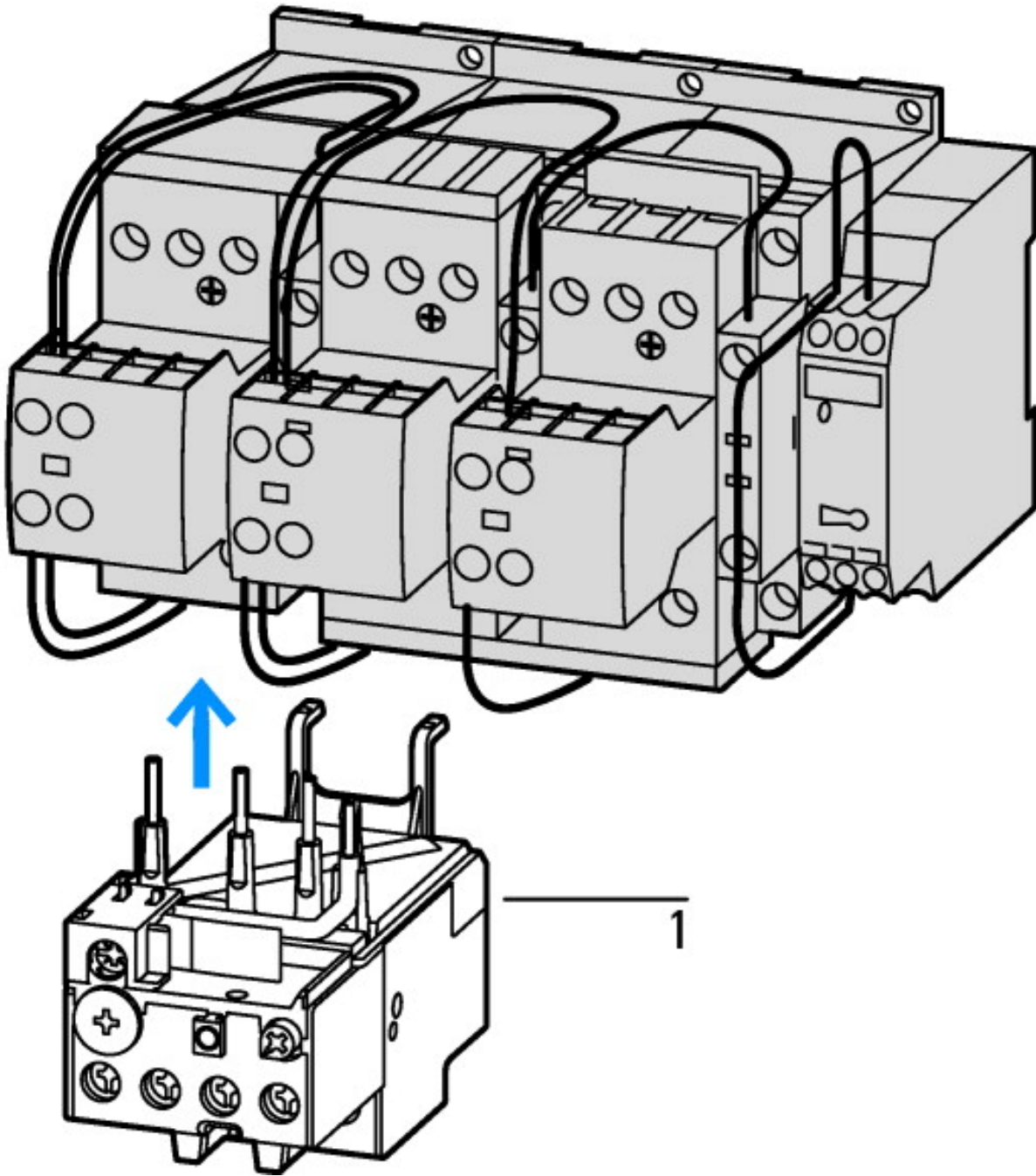

1: Overload relay

Dimensions

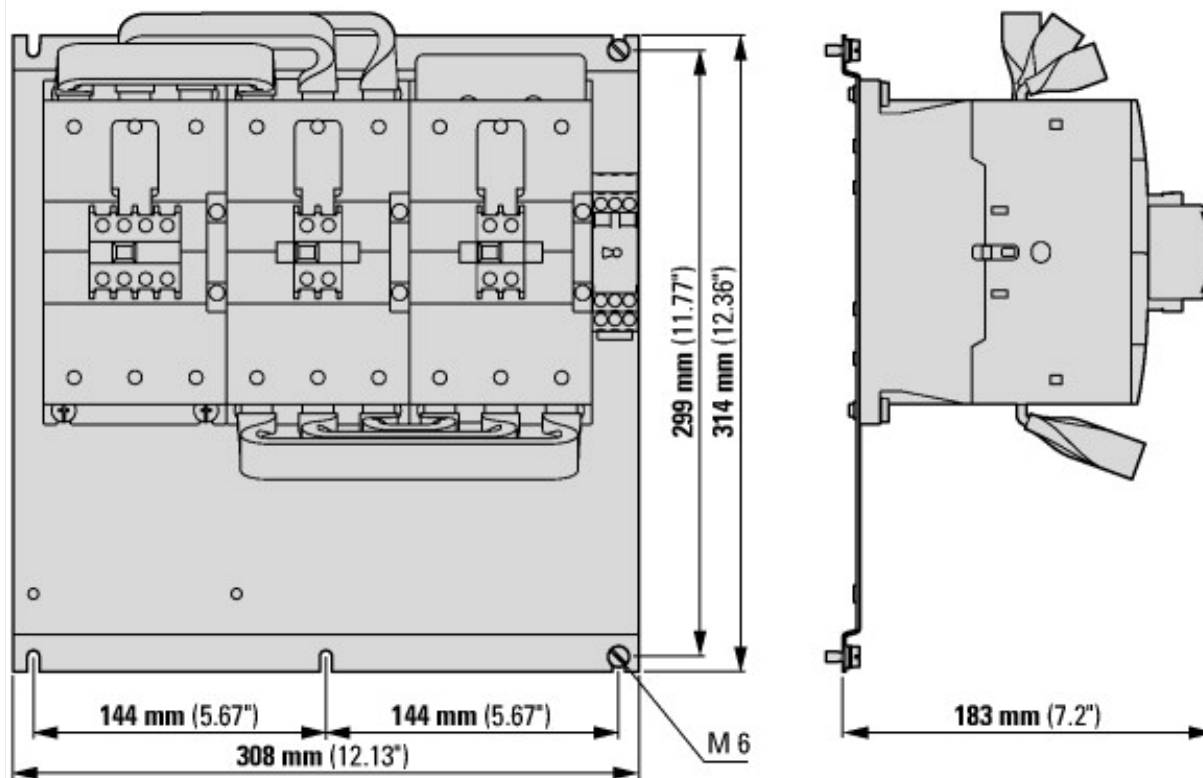

Additional product information (links)

IL03407030Z (AWA2100-2139) Wiring for contactor combinations

IL03407030Z (AWA2100-2139) Wiring for contactor combinations

ftp://ftp.moeller.net/DOCUMENTATION/AWA_INSTRUCTIONS/IL03407030Z2011_07.pdf