



Contactor, 3p+2N/O+2N/C, 250kW/400V/AC3

Part no. DILM500/22(RA250)
Catalog No. 208213
Eaton Catalog No. XTCE500M22A
EL-Nummer (Norway) 4134086

Delivery program

Product range				Contactors
Application				Contactors for Motors
Subrange				Comfort devices greater than 170 A
Utilization category				AC-1: Non-inductive or slightly inductive loads, resistance furnaces NAC-3: Normal AC induction motors: starting, switch off during running AC-4: Normal AC induction motors: starting, plugging, reversing, inching
Connection technique				Screw connection
Rated operational current				
AC-3				
380 V 400 V	I_e	A		500
AC-1				
Conventional free air thermal current, 3 pole, 50 - 60 Hz				
Open				
at 40 °C	$I_{th} = I_e$	A		800
enclosed	I_{th}	A		600
Conventional free air thermal current, 1 pole				
open	I_{th}	A		1625
enclosed	I_{th}	A		1500
Max. rating for three-phase motors, 50 - 60 Hz				
AC-3				
220 V 230 V	P	kW		155
380 V 400 V	P	kW		265
660 V 690 V	P	kW		300
1000 V	P	kW		132
AC-4				
220 V 230 V	P	kW		112
380 V 400 V	P	kW		200
660 V 690 V	P	kW		240
1000 V	P	kW		132
Contact sequence				
Can be combined with auxiliary contact				DILM820-XHI...
Actuating voltage				RA 250: 110 - 250 V 40 - 60 Hz/110 - 350 V DC
Voltage AC/DC				AC and DC operation
Contacts				
N/O = Normally open				2 N/O
N/C = Normally closed				2 NC
Auxiliary contacts				
possible variants at auxiliary contact module fitting options				on the side: 2 x DILM820-XHI11(V)-SI; 2 x DILM820-XHI11-SA
Side mounting auxiliary contacts				
Instructions				integrated suppressor circuit in actuating electronics 660 V, 690 V or 1000 V: not directly reversing

Technical data

General

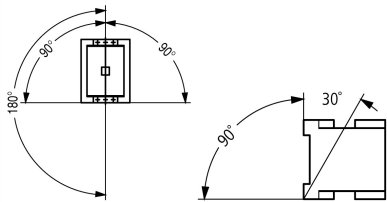
Standards			IEC/EN 60947, VDE 0660, UL, CSA
Lifespan, mechanical			
AC operated	Operations	$\times 10^6$	7
DC operated	Operations	$\times 10^6$	7
Operating frequency, mechanical			
AC operated	Operations/h		2000
DC operated	Operations/h		2000
Climatic proofing			Damp heat, constant, to IEC 60068-2-78 Damp heat, cyclic, to IEC 60068-2-30
Ambient temperature			
Open		°C	-40 - +60
Enclosed		°C	-40 - +40
Storage		°C	-40 - +80
Mounting position			
Mechanical shock resistance (IEC/EN 60068-2-27)			
Half-sinusoidal shock, 10 ms			
Main contacts			
N/O contact		g	10
Auxiliary contacts			
N/O contact		g	10
N/C contact		g	8
Degree of Protection			IP00
Protection against direct contact when actuated from front (EN 50274)			Finger and back-of-hand proof with terminal shroud or terminal block
Weight			
AC operated		kg	8.66
DC operated		kg	8.66
Weight		kg	8.66
Terminal capacity main cable			
Flexible with cable lug		mm ²	50 - 240
Stranded with cable lug		mm ²	70 - 240
Solid or stranded		AWG	2/0 - 500 MCM
Flat conductor	Lamellenzahl x Breite x Dicke	mm	Fixing with flat cable terminal or cable terminal blocks See terminal capacity for cable terminal blocks
Busbar	Width	mm	30
Main cable connection screw/bolt			M10
Tightening torque		Nm	24
Terminal capacity control circuit cables			
Solid		mm ²	1 x (0.75 - 2.5) 2 x (0.75 - 2.5)
Flexible with ferrule		mm ²	1 x (0.75 - 2.5) 2 x (0.75 - 2.5)
Solid or stranded		AWG	2 x (18 - 12)
Control circuit cable connection screw/bolt			M3.5
Tightening torque		Nm	1.2
Tool			
Main cable			
Width across flats		mm	16
Control circuit cables			
Pozidriv screwdriver		Size	2

Main conducting paths

Rated impulse withstand voltage	U_{imp}	V AC	8000
Overtoltage category/pollution degree			III/3
Rated insulation voltage	U_i	V AC	1000
Rated operational voltage	U_e	V AC	1000
Safe isolation to EN 61140			
between coil and contacts		V AC	500
between the contacts		V AC	500
Making capacity (p.f. to IEC/EN 60947)		A	5500
Breaking capacity			
220 V 230 V		A	5000
380 V 400 V		A	5000
500 V		A	5000
660 V 690 V		A	5000
1000 V		A	950
Component lifespan			AC1: See → Engineering, characteristic curves AC3: See → Engineering, characteristic curves AC4: See → Engineering, characteristic curves
Short-circuit rating			
Short-circuit protection maximum fuse			
Type "2" coordination			
400 V	gG/gL 500 V	A	500
690 V	gG/gL 690 V	A	500
1000 V	gG/gL 1000 V	A	200
Type "1" coordination			
400 V	gG/gL 500 V	A	630
690 V	gG/gL 690 V	A	630
1000 V	gG/gL 1000 V	A	250

AC

AC-1			
Rated operational current			
Conventional free air thermal current, 3 pole, 50 - 60 Hz			
Open			
at 40 °C	$I_{th} = I_e$	A	800
at 50 °C	$I_{th} = I_e$	A	715
at 55 °C	$I_{th} = I_e$	A	682
at 60 °C	$I_{th} = I_e$	A	650
enclosed	I_{th}	A	600
Notes			At maximum permissible ambient air temperature.
Conventional free air thermal current, 1 pole			
Note			at maximum permissible ambient air temperature
open	I_{th}	A	1625
enclosed	I_{th}	A	1500
AC-3			
Rated operational current			
Open, 3-pole: 50 – 60 Hz			
220 V 230 V	I_e	A	500
240 V	I_e	A	500
380 V 400 V	I_e	A	500
415 V	I_e	A	500
440V	I_e	A	500
500 V	I_e	A	500
660 V 690 V	I_e	A	325
1000 V	I_e	A	95

Motor rating	P	kWh	
220 V 230 V	P	kW	155
240V	P	kW	170
380 V 400 V	P	kW	265
415 V	P	kW	290
440 V	P	kW	315
500 V	P	kW	355
660 V 690 V	P	kW	300
1000 V	P	kW	132
AC-4			
Rated operational current			
Open, 3-pole: 50 – 60 Hz			
220 V 230 V	I_e	A	360
240 V	I_e	A	360
380 V 400 V	I_e	A	360
415 V	I_e	A	360
440 V	I_e	A	360
500 V	I_e	A	360
660 V 690 V	I_e	A	260
1000 V	I_e	A	95
Motor rating	P	kWh	
220 V 230 V	P	kW	112
240 V	P	kW	122
380 V 400 V	P	kW	200
415 V	P	kW	216
440 V	P	kW	229
500 V	P	kW	250
660 V 690 V	P	kW	240
1000 V	P	kW	132

Condensator operation

Individual compensation, rated operational current I_e of three-phase capacitors			
Open			
up to 525 V		A	307
690 V		A	177
Max. inrush current peak		$\times I_e$	30
Component lifespan	Operations	$\times 10^6$	0.1
Max. operating frequency		Ops/h	200

DC

Rated operational current, open			
DC-1			
Notes			see DILDC300/DILDC600 or on request

Current heat loss

3 pole, at I_{th} (60°)		W	113
Current heat loss at I_e to AC-3/400 V		W	58

Magnet systems

Voltage tolerance			
U_S			110 - 250 V 40-60 Hz 110 - 350 V DC
AC operated	Pick-up	$\times U_S$	$0.7 \times U_{S \min} - 1.15 \times U_{S \max}$
DC operated	Pick-up	$\times U_S$	$0.7 \times U_{S \min} - 1.15 \times U_{S \max}$
AC operated	Drop-out	$\times U_S$	$0.2 \times U_{S \max} - 0.6 \times U_{S \min}$
DC operated	Drop-out	$\times U_S$	$0.2 \times U_{S \max} - 0.6 \times U_{S \min}$
Power consumption of the coil in a cold state and $1.0 \times U_c$			
Note on power consumption			Control transformer with $u_k \leq 0.6$
Pull-in power	Pick-up	VA	450

Pull-in power	Pick-up	W	350
Sealing power	Sealing	VA	9.5
Sealing power	Sealing	W	7.9
Duty factor		% DF	100
Changeover time at 100 % U _C (recommended value)			
Main contacts			
Closing delay		ms	80
Opening delay		ms	110
Behaviour in marginal and transitional conditions			
Sealing			
Voltage interruptions			
(0 ... 0.2 x U _{C min}) \leq 10 ms			Time is bridged successfully
(0 ... 0.2 x U _{C min}) > 10 ms			Drop-out of the contactor
Voltage drops			
(0.2 ... 0.6 x U _{C min}) \leq 12 ms			Time is bridged successfully
(0.2 ... 0.6 x U _{C min}) > 12 ms			Drop-out of the contactor
(0.6 ... 0.7 x U _{C min})			Contactors remains switched on
Excess voltage			
(1.15 ... 1.3 x U _{C max})			Contactors remains switched on
Pick-up phase			
(0 ... 0.7 x U _{C min})			Contactors does not switch on
(0.7 x U _{C min} ... 1.15 x U _{C max})			Contactors switches on with certainty
Admissible transitional contact resistance (of the external control circuit device when actuating A11)		mΩ	\leq 500
PLC signal level (A3 - A4) to IEC/EN 61131-2 (type 2)			
High		V	15
Low		V	5

Electromagnetic compatibility (EMC)

Electromagnetic compatibility			This product is designed for operation in industrial environments (environment 2). The use in residential environments (environment 1) could cause electrical interference so that addition suppression must be planned.
-------------------------------	--	--	--

Rating data for approved types

Switching capacity			
Maximum motor rating			
Three-phase			
200 V 208 V		HP	150
230 V 240 V		HP	200
460 V 480 V		HP	400
575 V 600 V		HP	500
General use		A	550
Auxiliary contacts			
Pilot Duty			
AC operated			A600
DC operated			P300
General Use			
AC		V	600
AC		A	15
DC		V	250
DC		A	1
Short Circuit Current Rating			
Basic Rating			
SCCR		kA	30
max. Fuse		A	800

max. CB	A	600
480 V High Fault		
SCCR (fuse)	kA	30/100
max. Fuse	A	800/600 Class J
SCCR (CB)	kA	100
max. CB	A	600
600 V High Fault		
SCCR (fuse)	kA	30/100
max. Fuse	A	800/600 Class J
SCCR (CB)	kA	30
max. CB	A	600
Special Purpose Ratings		
Definite Purpose Ratings (100,000 cycles acc. to UL 1995)		
LRA 480V 60Hz 3phase	A	3900
FLA 480V 60Hz 3phase	A	635
LRA 600V 60Hz 3phase	A	3120
FLA 600V 60Hz 3phase	A	520

Design verification as per IEC/EN 61439

Technical data for design verification			
Rated operational current for specified heat dissipation	I_n	A	500
Heat dissipation per pole, current-dependent	P_{vid}	W	19.33
Equipment heat dissipation, current-dependent	P_{vid}	W	0
Static heat dissipation, non-current-dependent	P_{vs}	W	7.9
Heat dissipation capacity	P_{diss}	W	0
Operating ambient temperature max.		°C	-40
Operating ambient temperature max.		°C	60
IEC/EN 61439 design verification			
10.2 Strength of materials and parts			
10.2.2 Corrosion resistance			
10.2.3.1 Verification of thermal stability of enclosures			Meets the product standard's requirements.
10.2.3.2 Verification of resistance of insulating materials to normal heat			Meets the product standard's requirements.
10.2.3.3 Verification of resistance of insulating materials to abnormal heat and fire due to internal electric effects			Meets the product standard's requirements.
10.2.4 Resistance to ultra-violet (UV) radiation			
10.2.5 Lifting			Does not apply, since the entire switchgear needs to be evaluated.
10.2.6 Mechanical impact			
10.2.7 Inscriptions			Meets the product standard's requirements.
10.3 Degree of protection of ASSEMBLIES			
10.4 Clearances and creepage distances			
10.5 Protection against electric shock			Does not apply, since the entire switchgear needs to be evaluated.
10.6 Incorporation of switching devices and components			
10.7 Internal electrical circuits and connections			Is the panel builder's responsibility.
10.8 Connections for external conductors			
10.9 Insulation properties			
10.9.2 Power-frequency electric strength			Is the panel builder's responsibility.
10.9.3 Impulse withstand voltage			Is the panel builder's responsibility.
10.9.4 Testing of enclosures made of insulating material			Is the panel builder's responsibility.
10.10 Temperature rise			
10.11 Short-circuit rating			Is the panel builder's responsibility. The specifications for the switchgear must be observed.
10.12 Electromagnetic compatibility			
10.13 Mechanical function			The device meets the requirements, provided the information in the instruction leaflet (IL) is observed.

Technical data ETIM 6.0

Low-voltage industrial components (EG000017) / Power contactor, AC switching (EC000066)		
Electric engineering, automation, process control engineering / Low-voltage switch technology / Contactor (LV) / Power contactor, AC switching (ecl@ss8.1-27-37-10-03 [AAB718012])		
Rated control supply voltage Us at AC 50HZ	V	110 - 250
Rated control supply voltage Us at AC 60HZ	V	110 - 250
Rated control supply voltage Us at DC	V	110 - 250
Voltage type for actuating		AC/DC
Rated operation current Ie at AC-1, 400 V	A	800
Rated operation current Ie at AC-3, 400 V	A	500
Rated operation power at AC-3, 400 V	kW	250
Rated operation current Ie at AC-4, 400 V	A	360
Rated operation power Ie at AC-4, 400 V	kW	200
Modular version		No
Number of auxiliary contacts as normally open contact		2
Number of auxiliary contacts as normally closed contact		2
Type of electrical connection of main circuit		Rail connection
Number of normally closed contacts as main contact		0
Number of main contacts as normally open contact		3

Approvals

Product Standards		IEC/EN 60947-4-1; UL 60947-4-1; CSA - C22.2 No. 60947-4-1-14; CE marking
UL File No.		E29096
UL Category Control No.		NLDX
CSA File No.		012528
CSA Class No.		3211-04
North America Certification		UL listed, CSA certified
Specially designed for North America		No

Characteristics

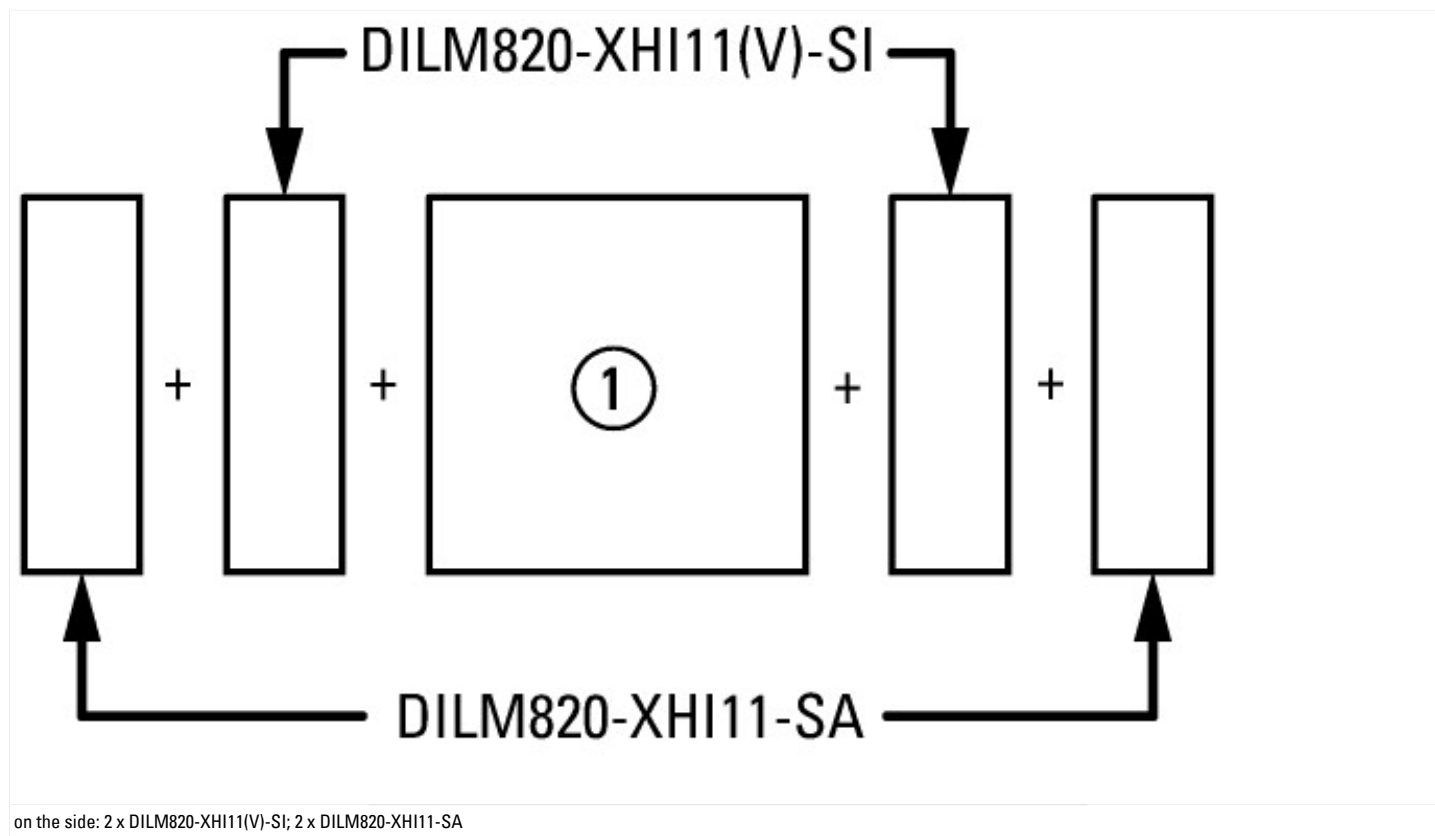

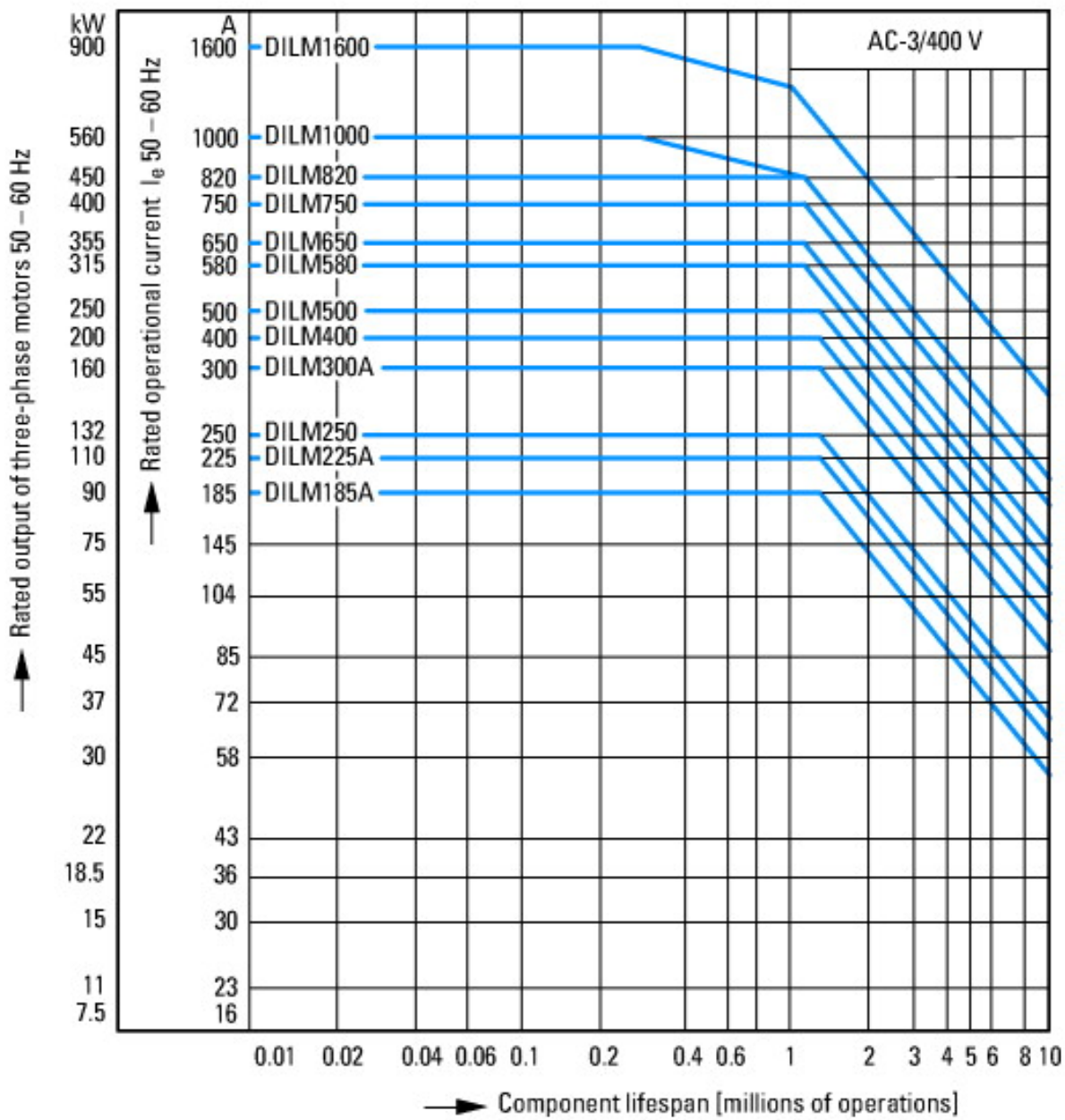

- Normal switching duty
- Normal AC induction motor
- Operating characteristics
- Switch on: from stop
- Switch off: during run
- Electrical characteristics:
- Switch on: up to 6 x Rated motor current
- Switch off: up to 1 x Rated motor current
- Utility category
- 100 % AC-3
- Typical Applications
- Compressors
- Lifts
- Mixers
- Pumps
- Escalators
- Agitators
- fan
- Conveyor belts
- Centrifuges
- Hinged flaps
- Bucket-elevator
- Air-conditioning systems
- General drives for manufacturing and processing machines

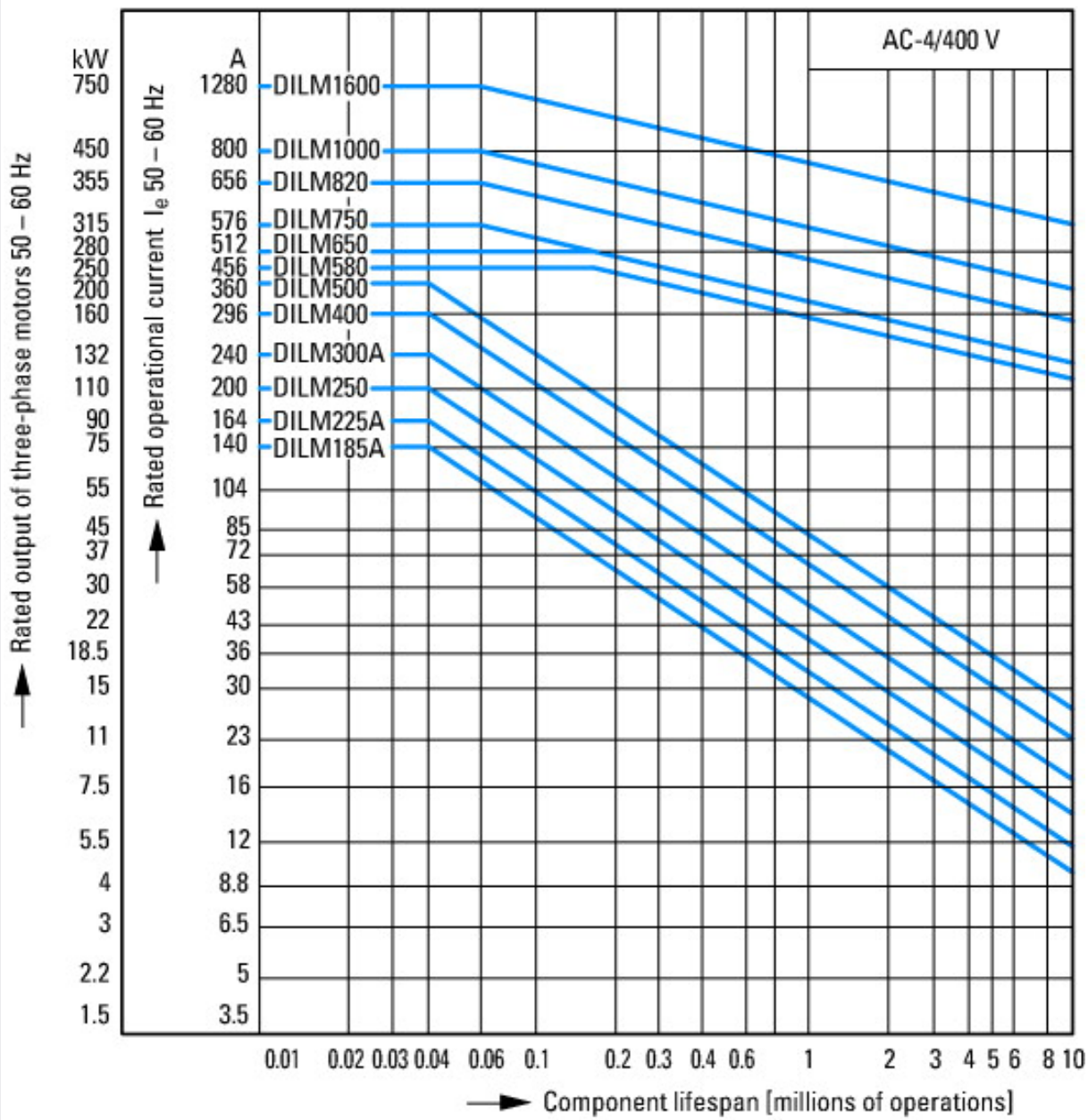

Extreme switching duty
 Squirrel-cage motor
 Operating characteristics
 Inching, plugging, reversing
 Electrical characteristics
 Make: up to 6 x rated motor current
 Break: up to 6 x rated motor current
 Utilization category
 100 % AC-4
 Typical applications
 Printing presses
 Wire-drawing machines
 Centrifuges
 Special drives for manufacturing and processing machines



Switching conditions for 3 pole, non-motor loads
 Operating characteristics
 Non inductive and slightly inductive loads
 Electrical characteristics
 Switch on: 1 x rated operational current
 Switch off: 1 x rated operational current
 Utilization category
 100 % AC-1
 Typical examples of application
 Electric heat

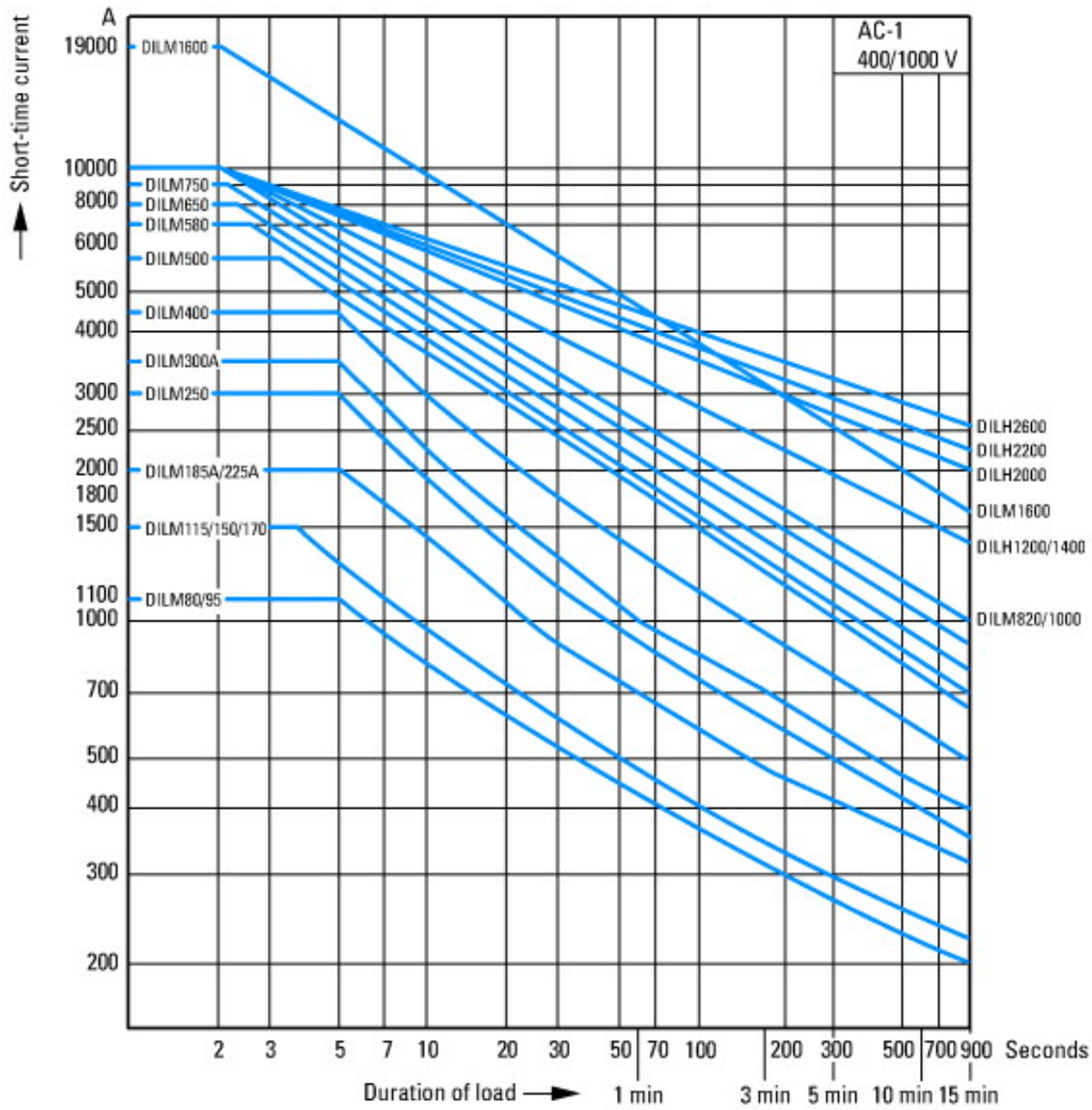

Short-time loading, 3-pole
Time interval between two loading cycles: 15 minutes

Dimensions

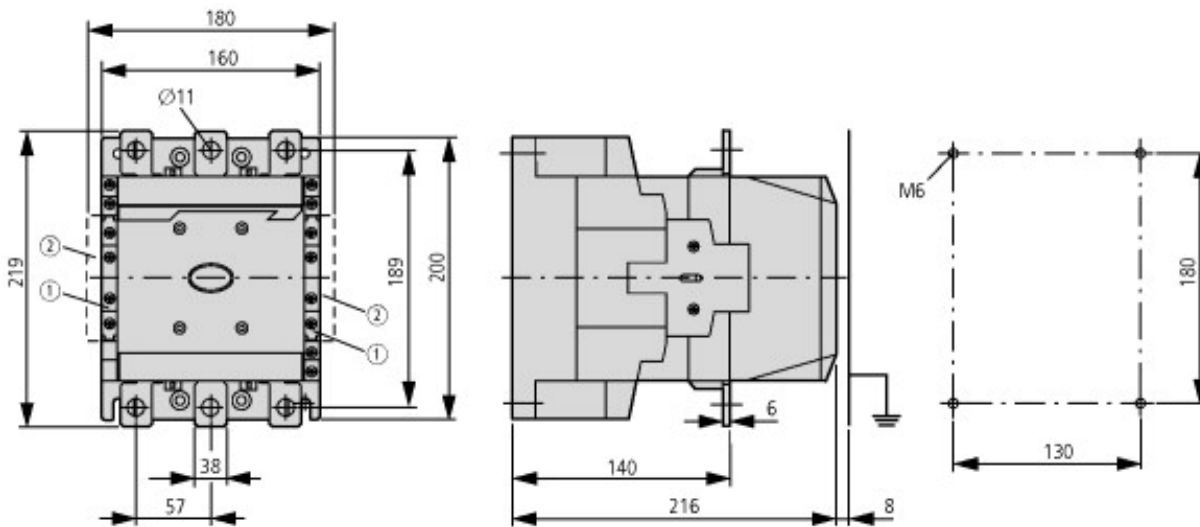

- ① DILM820-XHI11(V)-SI
- ② DILM820-XHI11-SA

Additional product information (links)

IL03406002Z (AWA2100-1639) Contactors >170 A

IL03406002Z (AWA2100-1639) Contactors >170 A ftp://ftp.moeller.net/DOCUMENTATION/AWA_INSTRUCTIONS/IL03406002Z2012_09.pdf

UL/CSA: Approved rating data <http://de.ecat.moeller.net/flip-cat/?edition=HPLTE&startpage=5.84>

UL/CSA: UL/CSA: Short Circuit Current Rating (SCCR) <http://de.ecat.moeller.net/flip-cat/?edition=HPLTE&startpage=5.86>

Switchgear of Power Factor Correction Systems http://www.moeller.net/binary/ver_techpapers/ver934en.pdf

X-Start - Modern Switching Installations Efficiently Fitted and Wired Securely http://www.moeller.net/binary/ver_techpapers/ver938en.pdf

Mirror Contacts for Highly-Reliable Information Relating to Safety-Related Control Functions http://www.moeller.net/binary/ver_techpapers/ver944en.pdf

Effect of the Cable Capacitance of Long Control Cables on the Actuation of Contactors http://www.moeller.net/binary/ver_techpapers/ver949en.pdf

Motor starters and "Special Purpose Ratings" for the North American market http://www.moeller.net/binary/ver_techpapers/ver953en.pdf

Switchgear for Luminaires http://www.moeller.net/binary/ver_techpapers/ver955en.pdf

Standard Compliant and Functionally Safe Engineering Design with Mechanical Auxiliary Contacts http://www.moeller.net/binary/ver_techpapers/ver956en.pdf

The Interaction of Contactors with PLCs http://www.moeller.net/binary/ver_techpapers/ver957en.pdf

Busbar Component Adapters for modern Industrial control panels http://www.moeller.net/binary/ver_techpapers/ver960en.pdf