

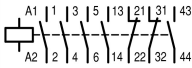
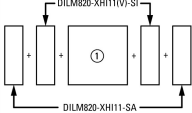

Contactor, 3p+2N/O+2N/C, 1000A/AC3

Part no. DILM1000/22(RA250)
Catalog No. 267214
Eaton Catalog No. XTCEC10N22A
EL-Nummer (Norway) 4130462

Delivery program

| | | | | |
|---|----------------|----|--|--|
| Product range | | | | Contactors |
| Application | | | | Contactors for Motors |
| Subrange | | | | Comfort devices greater than 170 A |
| Utilization category | | | | AC-1: Non-inductive or slightly inductive loads, resistance furnaces NAC-3: Normal AC induction motors: starting, switch off during running AC-4: Normal AC induction motors: starting, plugging, reversing, inching |
| Connection technique | | | | Screw connection |
| Rated operational current | | | | |
| AC-3 | | | | |
| 380 V 400 V | I_e | A | | 1000 |
| AC-1 | | | | |
| Conventional free air thermal current, 3 pole, 50 - 60 Hz | | | | |
| Open | | | | |
| at 40 °C | $I_{th} = I_e$ | A | | 1225 |
| Conventional free air thermal current, 1 pole | | | | |
| open | I_{th} | A | | 2500 |
| Max. rating for three-phase motors, 50 - 60 Hz | | | | |
| AC-3 | | | | |
| 220 V 230 V | P | kW | | 315 |
| 380 V 400 V | P | kW | | 560 |
| 660 V 690 V | P | kW | | 1000 |
| 1000 V | P | kW | | 1100 |
| AC-4 | | | | |
| 220 V 230 V | P | kW | | 260 |
| 380 V 400 V | P | kW | | 450 |
| 660 V 690 V | P | kW | | 780 |
| 1000 V | P | kW | | 1000 |
| Contact sequence | | | |  |
| Can be combined with auxiliary contact | | | | DILM820-XHI... |
| Actuating voltage | | | | RA 250: 110 - 250 V 40 - 60 Hz/110 - 350 V DC |
| Voltage AC/DC | | | | AC and DC operation |
| Contacts | | | | |
| N/O = Normally open | | | | 2 N/O |
| N/C = Normally closed | | | | 2 NC |
| Auxiliary contacts | | | | |
| possible variants at auxiliary contact module fitting options | | | | on the side: 2 x DILM820-XHI11(V)-SI; 2 x DILM820-XHI11-SA |
| Side mounting auxiliary contacts | | | |  |
| Instructions | | | | integrated suppressor circuit in actuating electronics 660 V, 690 V or 1000 V: not directly reversing |

Technical data

| | | | | |
|----------------------|--|--|--|---------------------------------|
| General | | | | |
| Standards | | | | IEC/EN 60947, VDE 0660, UL, CSA |
| Lifespan, mechanical | | | | |

| | | | |
|--|--------------|-----------------|--------------------------------------|
| AC operated | Operations | $\times 10^6$ | 5 |
| DC operated | Operations | $\times 10^6$ | 5 |
| Operating frequency, mechanical | | | |
| AC operated | Operations/h | | 1000 |
| DC operated | Operations/h | | 1000 |
| Climatic proofing | | | |
| Damp heat, constant, to IEC 60068-2-78 Damp heat, cyclic, to IEC 60068-2-30 | | | |
| Ambient temperature | | | |
| Open | | °C | -40 - +60 |
| Enclosed | | °C | -40 - +40 |
| Storage | | °C | -40 - +80 |
| Mounting position | | | |
| | | | |
| Mechanical shock resistance (IEC/EN 60068-2-27) | | | |
| Half-sinusoidal shock, 10 ms | | | |
| Main contacts | | | |
| N/O contact | | g | 10 |
| Auxiliary contacts | | | |
| N/O contact | | g | 10 |
| N/C contact | | g | 8 |
| Degree of Protection | | | |
| IP00 | | | |
| Protection against direct contact when actuated from front (EN 50274) | | | |
| Finger and back-of-hand proof with terminal shroud or terminal block | | | |
| Weight | | | |
| AC operated | | kg | 17.34 |
| DC operated | | kg | 17.34 |
| Weight | | kg | 17.34 |
| Terminal capacity main cable | | | |
| Flexible with cable lug | | mm ² | 50 - 240 |
| Stranded with cable lug | | mm ² | 70 - 240 |
| Solid or stranded | | AWG | 2/0 - 500 MCM |
| Busbar | Width | mm | 60 |
| Main cable connection screw/bolt | | | |
| M12 | | | |
| Tightening torque | | | |
| Nm 35 | | | |
| Terminal capacity control circuit cables | | | |
| Solid | | mm ² | 1 x (0.75 - 2.5) 2 x (0.75 - 2.5) |
| Flexible with ferrule | | mm ² | 1 x (0.75 - 2.5) 2 x (0.75 - 2.5) |
| Solid or stranded | | AWG | 2 x (18 - 12) |
| Control circuit cable connection screw/bolt | | | |
| M3.5 | | | |
| Tightening torque | | | |
| Nm 1.2 | | | |
| Tool | | | |
| Main cable | | | |
| Width across flats | | mm | 18 |
| Control circuit cables | | | |
| Pozidriv screwdriver | | Size | 2 |

Main conducting paths

| | | | |
|---------------------------------------|-----------|------|-------|
| Rated impulse withstand voltage | U_{imp} | V AC | 8000 |
| Overvoltage category/pollution degree | | | III/3 |
| Rated insulation voltage | U_i | V AC | 1000 |
| Rated operational voltage | U_e | V AC | 1000 |
| Safe isolation to EN 61140 | | | |
| between coil and contacts | | V AC | 500 |
| between the contacts | | V AC | 500 |

| | | | |
|--|--------------|---|---|
| Making capacity (p.f. to IEC/EN 60947) | | A | 9840 |
| Breaking capacity | | | |
| 220 V 230 V | | A | 8200 |
| 380 V 400 V | | A | 8200 |
| 500 V | | A | 8200 |
| 660 V 690 V | | A | 8200 |
| 1000 V | | A | 5800 |
| Component lifespan | | | AC1: See → Engineering, characteristic curves AC3: See → Engineering, characteristic curves AC4: See → Engineering, characteristic curves |
| Short-circuit rating | | | |
| Short-circuit protection maximum fuse | | | |
| Type "2" coordination | | | |
| 400 V | gG/gL 500 V | A | 630 |
| 690 V | gG/gL 690 V | A | 630 |
| 1000 V | gG/gL 1000 V | A | 630 |
| Type "1" coordination | | | |
| 400 V | gG/gL 500 V | A | 1200 |
| 690 V | gG/gL 690 V | A | 1200 |
| 1000 V | gG/gL 1000 V | A | 800 |

AC

| | | | |
|---|----------------|-----|--|
| AC-1 | | | |
| Rated operational current | | | |
| Conventional free air thermal current, 3 pole, 50 - 60 Hz | | | |
| Open | | | |
| at 40 °C | $I_{th} = I_e$ | A | 1225 |
| at 50 °C | $I_{th} = I_e$ | A | 1095 |
| at 55 °C | $I_{th} = I_e$ | A | 1044 |
| at 60 °C | $I_{th} = I_e$ | A | 1000 |
| Conventional free air thermal current, 1 pole | | | |
| Note | | | at maximum permissible ambient air temperature |
| open | I_{th} | A | 2500 |
| AC-3 | | | |
| Rated operational current | | | |
| Open, 3-pole: 50 – 60 Hz | | | |
| 220 V 230 V | I_e | A | 1000 |
| 240 V | I_e | A | 1000 |
| 380 V 400 V | I_e | A | 1000 |
| 415 V | I_e | A | 1000 |
| 440V | I_e | A | 1000 |
| 500 V | I_e | A | 1000 |
| 660 V 690 V | I_e | A | 1000 |
| 1000 V | I_e | A | 750 |
| Motor rating | P | kWh | |
| 220 V 230 V | P | kW | 315 |
| 240V | P | kW | 340 |
| 380 V 400 V | P | kW | 560 |
| 415 V | P | kW | 610 |
| 440 V | P | kW | 650 |
| 500 V | P | kW | 730 |
| 660 V 690 V | P | kW | 1000 |
| 1000 V | P | kW | 1100 |
| AC-4 | | | |
| Rated operational current | | | |

| | | | |
|--------------------------|-------|-----|------|
| Open, 3-pole: 50 – 60 Hz | | | |
| 220 V 230 V | I_e | A | 800 |
| 240 V | I_e | A | 800 |
| 380 V 400 V | I_e | A | 800 |
| 415 V | I_e | A | 800 |
| 440 V | I_e | A | 800 |
| 500 V | I_e | A | 800 |
| 660 V 690 V | I_e | A | 800 |
| 1000 V | I_e | A | 700 |
| Motor rating | P | kWh | |
| 220 V 230 V | P | kW | 260 |
| 240 V | P | kW | 280 |
| 380 V 400 V | P | kW | 450 |
| 415 V | P | kW | 490 |
| 440 V | P | kW | 520 |
| 500 V | P | kW | 590 |
| 660 V 690 V | P | kW | 780 |
| 1000 V | P | kW | 1000 |

Condensator operation

| | | | |
|--|------------|---------------|-----|
| Individual compensation, rated operational current I_e of three-phase capacitors | | | |
| Open | | | |
| up to 525 V | | A | 463 |
| 690 V | | A | 265 |
| Max. inrush current peak | | $\times I_e$ | 30 |
| Component lifespan | Operations | $\times 10^6$ | 0.1 |
| Max. operating frequency | | Ops/h | 200 |

Current heat loss

| | | | |
|--|--|---|----|
| 3 pole, at I_{th} (60°) | | W | 96 |
| Current heat loss at I_e to AC-3/400 V | | W | 96 |

Magnet systems

| | | | |
|--|----------|--------------|--|
| Voltage tolerance | | | |
| U_S | | | 110 - 250 V 40-60 Hz 110 - 350 V DC |
| AC operated | Pick-up | $\times U_S$ | $0.7 \times U_{S \min} - 1.15 \times U_{S \max}$ |
| DC operated | Pick-up | $\times U_S$ | $0.7 \times U_{S \min} - 1.15 \times U_{S \max}$ |
| AC operated | Drop-out | $\times U_S$ | $0.2 \times U_{S \max} - 0.6 \times U_{S \min}$ |
| DC operated | Drop-out | $\times U_S$ | $0.2 \times U_{S \max} - 0.6 \times U_{S \min}$ |
| Power consumption of the coil in a cold state and $1.0 \times U_C$ | | | |
| Note on power consumption | | | Control transformer with $u_k \leq 0.7$ |
| Pull-in power | Pick-up | VA | 800 |
| Pull-in power | Pick-up | W | 700 |
| Sealing power | Sealing | VA | 7.5 |
| Sealing power | Sealing | W | 6.5 |
| Duty factor | | % DF | 100 |
| Changeover time at 100 % U_C (recommended value) | | | |
| Main contacts | | | |
| Closing delay | | ms | 70 |
| Opening delay | | ms | 110 |
| Behaviour in marginal and transitional conditions | | | |
| Sealing | | | |
| Voltage interruptions | | | |
| $(0 \dots 0.2 \times U_{C \min}) \leq 10 \text{ ms}$ | | | Time is bridged successfully |
| $(0 \dots 0.2 \times U_{C \min}) > 10 \text{ ms}$ | | | Drop-out of the contactor |
| Voltage drops | | | |

| | | | |
|--|----|--------|--------------------------------------|
| $(0.2 \dots 0.6 \times U_{c \min}) \leq 12 \text{ ms}$ | | | Time is bridged successfully |
| $(0.2 \dots 0.6 \times U_{c \min}) > 12 \text{ ms}$ | | | Drop-out of the contactor |
| $(0.6 \dots 0.7 \times U_{c \min})$ | | | Contactor remains switched on |
| Excess voltage | | | |
| $(1.15 \dots 1.3 \times U_{c \max})$ | | | Contactor remains switched on |
| Pick-up phase | | | |
| $(0 \dots 0.7 \times U_{c \min})$ | | | Contactor does not switch on |
| $(0.7 \times U_{c \min} \dots 1.15 \times U_{c \max})$ | | | Contactor switches on with certainty |
| Admissible transitional contact resistance (of the external control circuit device when actuating A11) | mΩ | \leq | 500 |
| PLC signal level (A3 - A4) to IEC/EN 61131-2 (type 2) | | | |
| High | V | | 15 |
| Low | V | | 5 |

Electromagnetic compatibility (EMC)

| | | | |
|-------------------------------|--|--|--|
| Electromagnetic compatibility | | | This product is designed for operation in industrial environments (environment 2). The use in residential environments (environment 1) could cause electrical interference so that additional suppression must be planned. |
|-------------------------------|--|--|--|

Rating data for approved types

| | | | |
|---|----|------|------|
| Switching capacity | | | |
| Maximum motor rating | | | |
| Three-phase | | | |
| 230 V 240 V | HP | | 400 |
| 460 V 480 V | HP | | 800 |
| 575 V 600 V | HP | | 1000 |
| General use | A | | 1225 |
| Auxiliary contacts | | | |
| Pilot Duty | | | |
| AC operated | | | A600 |
| DC operated | | | P300 |
| General Use | | | |
| AC | V | | 600 |
| AC | A | | 15 |
| DC | V | | 250 |
| DC | A | | 1 |
| Short Circuit Current Rating | | SCCR | |
| Basic Rating | | | |
| SCCR | kA | | 85 |
| max. Fuse | A | | 2000 |
| max. CB | A | | 1200 |
| 480 V High Fault | | | |
| SCCR (fuse) | kA | | 85 |
| max. Fuse | A | | 2000 |
| SCCR (CB) | kA | | 85 |
| max. CB | A | | 1200 |
| 600 V High Fault | | | |
| SCCR (fuse) | kA | | 85 |
| max. Fuse | A | | 2000 |
| SCCR (CB) | kA | | 85 |
| max. CB | A | | 1200 |
| Special Purpose Ratings | | | |
| Definite Purpose Ratings (100,000 cycles acc. to UL 1995) | | | |
| LRA 480V 60Hz 3phase | A | | 6000 |
| FLA 480V 60Hz 3phase | A | | 1200 |
| LRA 600V 60Hz 3phase | A | | 6000 |

| | | |
|----------------------|---|------|
| FLA 600V 60Hz 3phase | A | 1200 |
|----------------------|---|------|

Design verification as per IEC/EN 61439

| Technical data for design verification | | | |
|--|------------|----|------|
| Rated operational current for specified heat dissipation | I_n | A | 1000 |
| Heat dissipation per pole, current-dependent | P_{vid} | W | 32 |
| Equipment heat dissipation, current-dependent | P_{vid} | W | 0 |
| Static heat dissipation, non-current-dependent | P_{vs} | W | 6.5 |
| Heat dissipation capacity | P_{diss} | W | 0 |
| Operating ambient temperature max. | | °C | -40 |
| Operating ambient temperature max. | | °C | 60 |
| IEC/EN 61439 design verification | | | |
| 10.2 Strength of materials and parts | | | |
| 10.2.2 Corrosion resistance | | | |
| 10.2.3.1 Verification of thermal stability of enclosures | | | |
| 10.2.3.2 Verification of resistance of insulating materials to normal heat | | | |
| 10.2.3.3 Verification of resistance of insulating materials to abnormal heat and fire due to internal electric effects | | | |
| 10.2.4 Resistance to ultra-violet (UV) radiation | | | |
| 10.2.5 Lifting | | | |
| 10.2.6 Mechanical impact | | | |
| 10.2.7 Inscriptions | | | |
| 10.3 Degree of protection of ASSEMBLIES | | | |
| 10.4 Clearances and creepage distances | | | |
| 10.5 Protection against electric shock | | | |
| 10.6 Incorporation of switching devices and components | | | |
| 10.7 Internal electrical circuits and connections | | | |
| 10.8 Connections for external conductors | | | |
| 10.9 Insulation properties | | | |
| 10.9.2 Power-frequency electric strength | | | |
| 10.9.3 Impulse withstand voltage | | | |
| 10.9.4 Testing of enclosures made of insulating material | | | |
| 10.10 Temperature rise | | | |
| 10.11 Short-circuit rating | | | |
| 10.12 Electromagnetic compatibility | | | |
| 10.13 Mechanical function | | | |

Technical data ETIM 6.0

| Low-voltage industrial components (EG000017) / Power contactor, AC switching (EC000066) | | | |
|--|--|----|-----------------|
| Electric engineering, automation, process control engineering / Low-voltage switch technology / Contactor (LV) / Power contactor, AC switching (ecl@ss8.1-27-37-10-03 [AAB718012]) | | | |
| Rated control supply voltage U_s at AC 50HZ | | V | 110 - 250 |
| Rated control supply voltage U_s at AC 60HZ | | V | 110 - 250 |
| Rated control supply voltage U_s at DC | | V | 110 - 250 |
| Voltage type for actuating | | | AC/DC |
| Rated operation current I_e at AC-1, 400 V | | A | 1225 |
| Rated operation current I_e at AC-3, 400 V | | A | 1000 |
| Rated operation power at AC-3, 400 V | | kW | 560 |
| Rated operation current I_e at AC-4, 400 V | | A | 800 |
| Rated operation power I_e at AC-4, 400 V | | kW | 450 |
| Modular version | | | No |
| Number of auxiliary contacts as normally open contact | | | 2 |
| Number of auxiliary contacts as normally closed contact | | | 2 |
| Type of electrical connection of main circuit | | | Rail connection |

| | | |
|--|--|---|
| Number of normally closed contacts as main contact | | 0 |
| Number of main contacts as normally open contact | | 3 |

Approvals

| | | |
|--------------------------------------|--|--|
| Product Standards | | IEC/EN 60947-4-1; UL 60947-4-1; CSA - C22.2 No. 60947-4-1-14; CE marking |
| UL File No. | | E29096 |
| UL Category Control No. | | NLDX |
| CSA File No. | | 012528 |
| CSA Class No. | | 3211-04 |
| North America Certification | | UL listed, CSA certified |
| Specially designed for North America | | No |

Characteristics

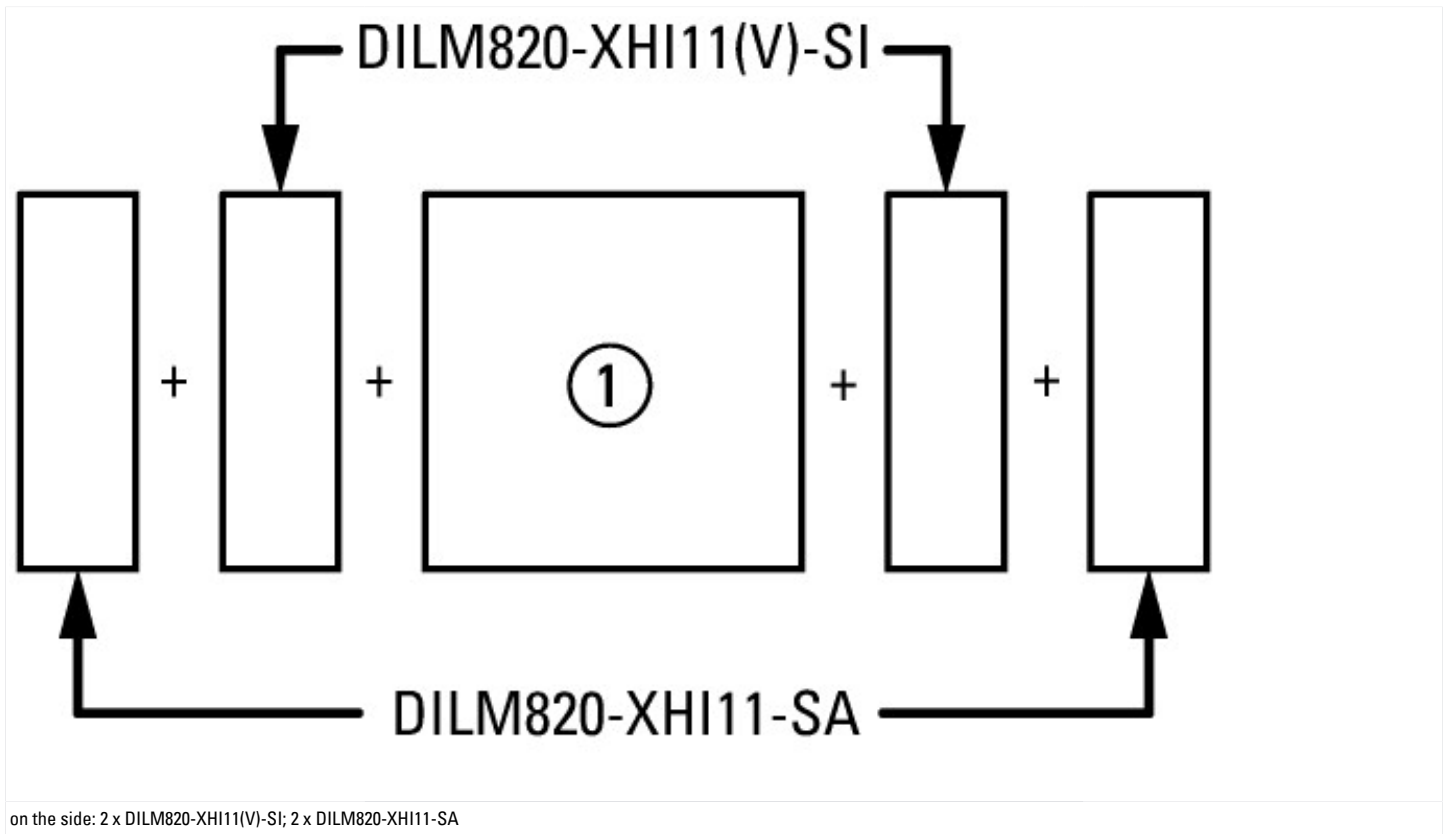

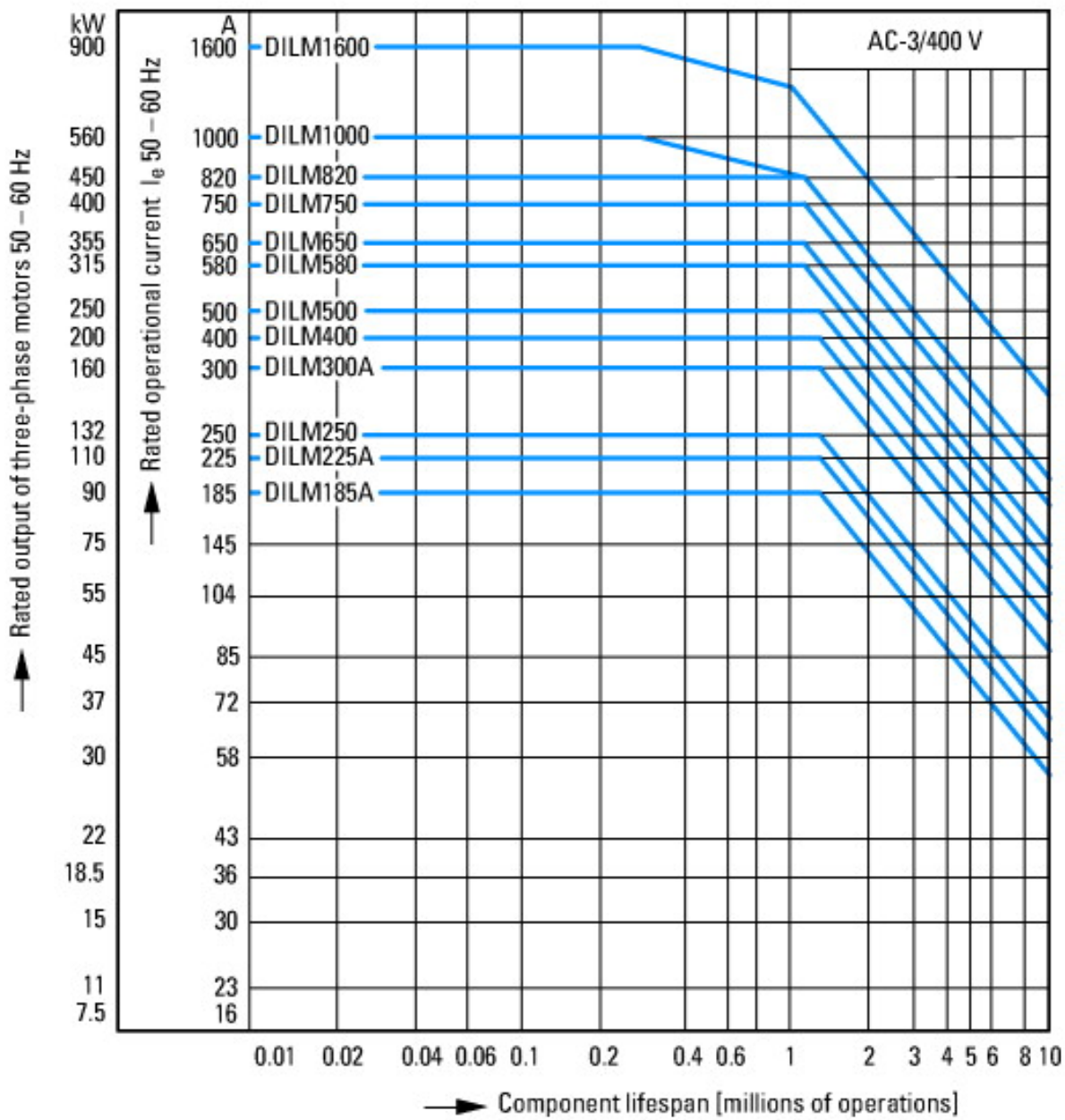

- Normal switching duty
- Normal AC induction motor
- Operating characteristics
- Switch on: from stop
- Switch off: during run
- Electrical characteristics:
- Switch on: up to 6 x Rated motor current
- Switch off: up to 1 x Rated motor current
- Utility category
- 100 % AC-3
- Typical Applications
- Compressors
- Lifts
- Mixers
- Pumps
- Escalators
- Agitators
- fan
- Conveyor belts
- Centrifuges
- Hinged flaps
- Bucket-elevator
- Air-conditioning systems
- General drives for manufacturing and processing machines

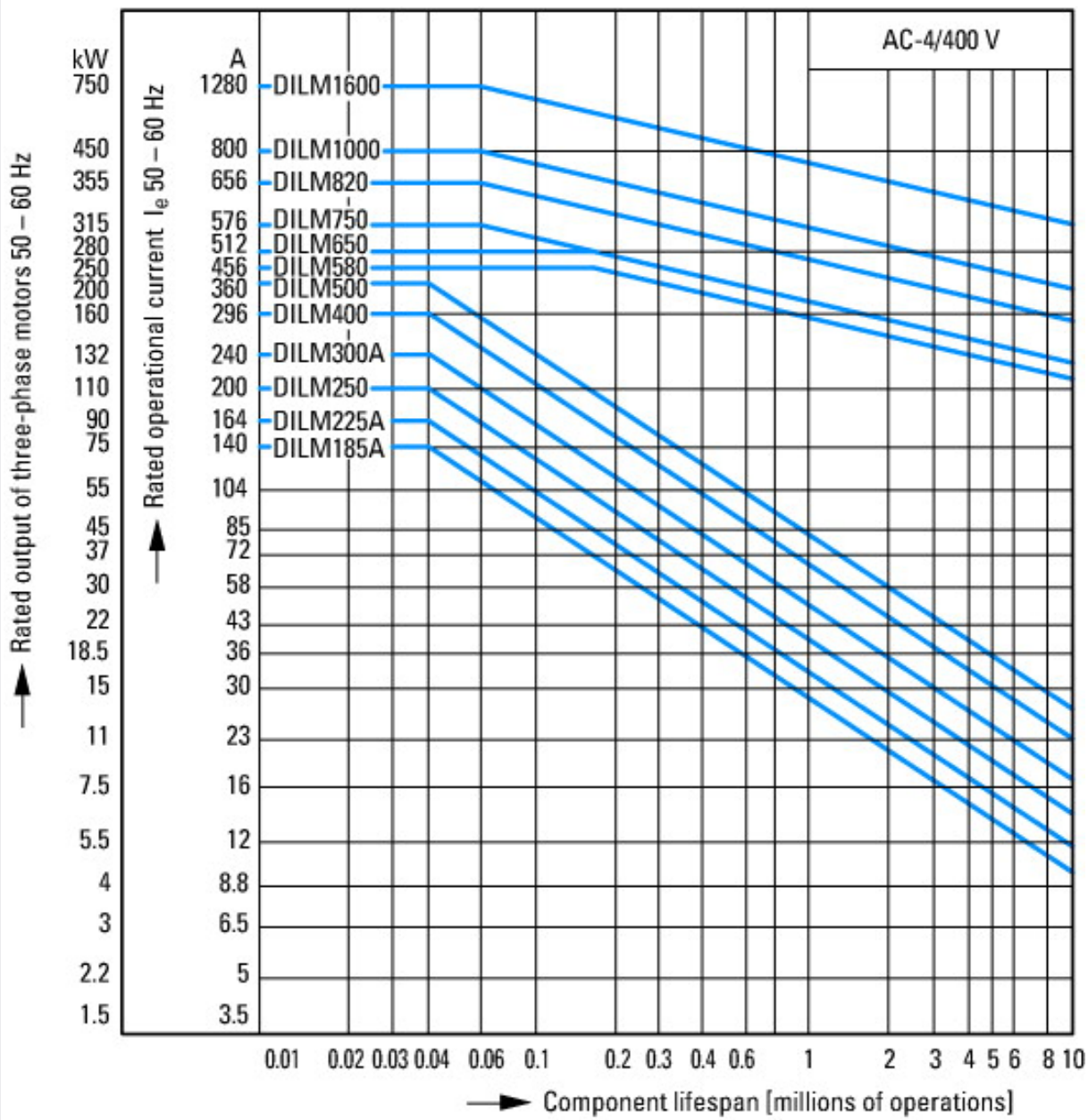

- Extreme switching duty
- Squirrel-cage motor
- Operating characteristics
- Inching, plugging, reversing
- Electrical characteristics
- Make: up to 6 x rated motor current
- Break: up to 6 x rated motor current
- Utilization category
- 100 % AC-4
- Typical applications
- Printing presses
- Wire-drawing machines
- Centrifuges
- Special drives for manufacturing and processing machines

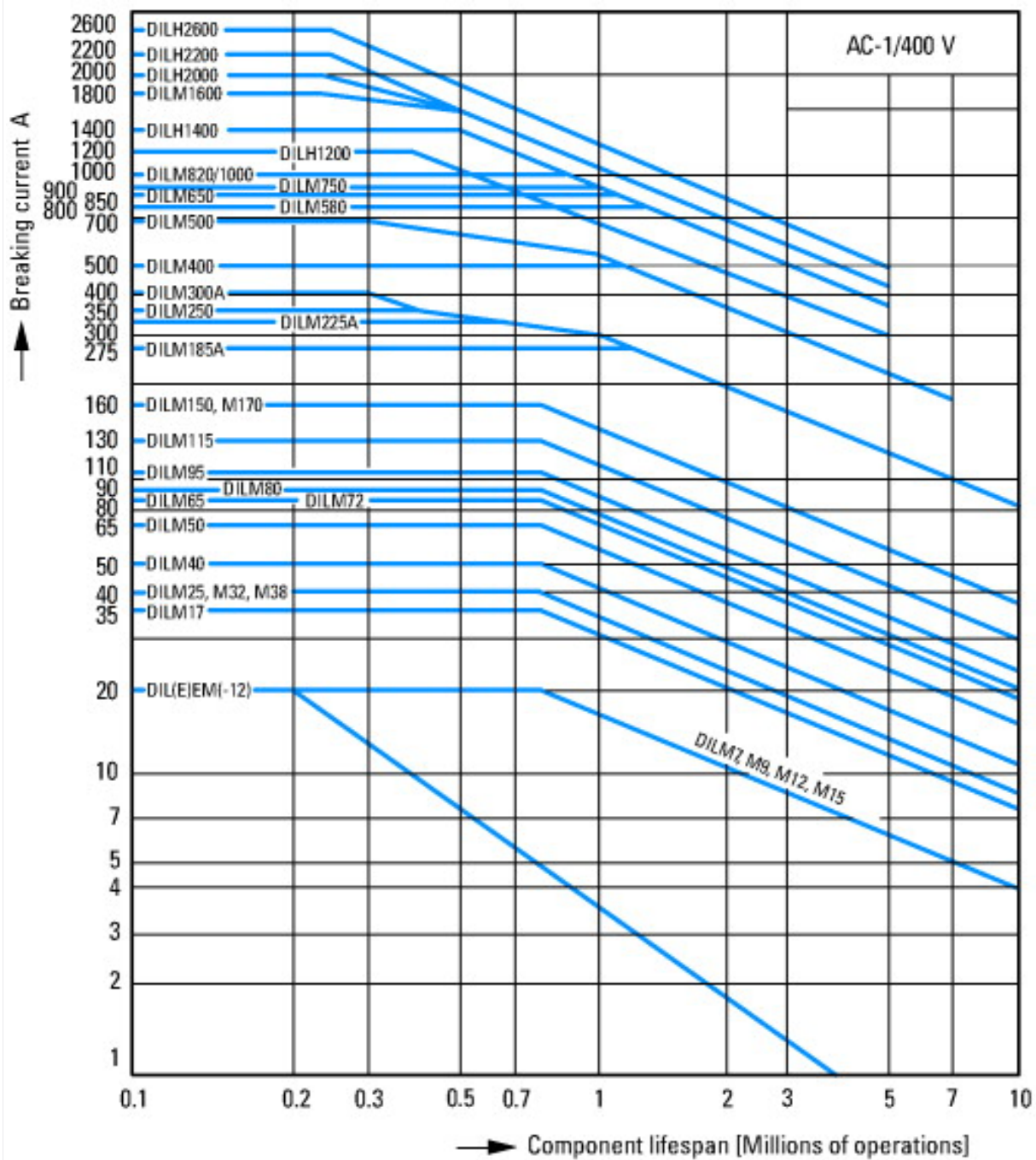

Switching conditions for 3 pole, non-motor loads
 Operating characteristics
 Non inductive and slightly inductive loads
 Electrical characteristics
 Switch on: 1 x rated operational current
 Switch off: 1 x rated operational current
 Utilization category
 100 % AC-1
 Typical examples of application
 Electric heat

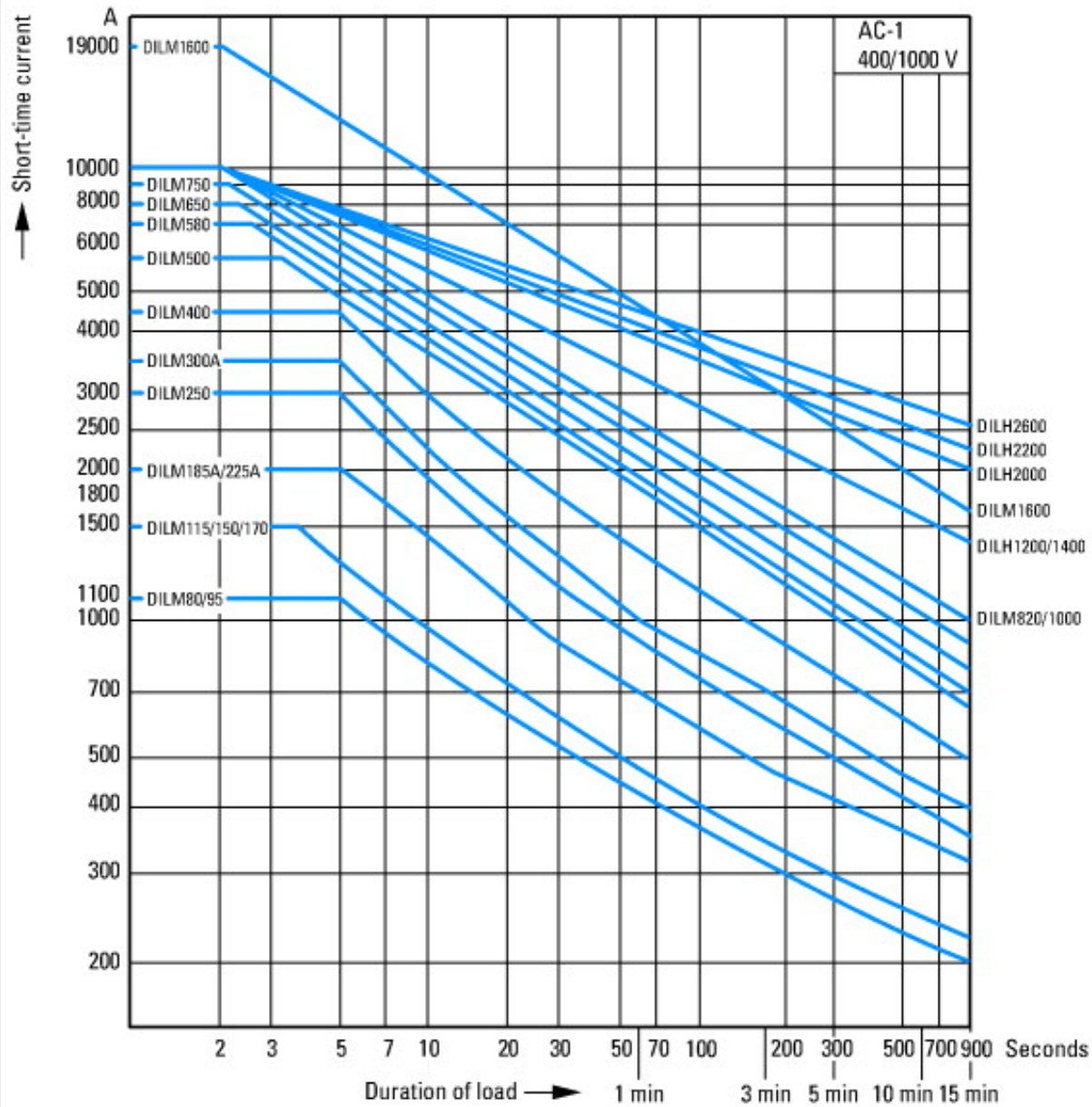

Short-time loading, 3-pole
Time interval between two loading cycles: 15 minutes

Dimensions

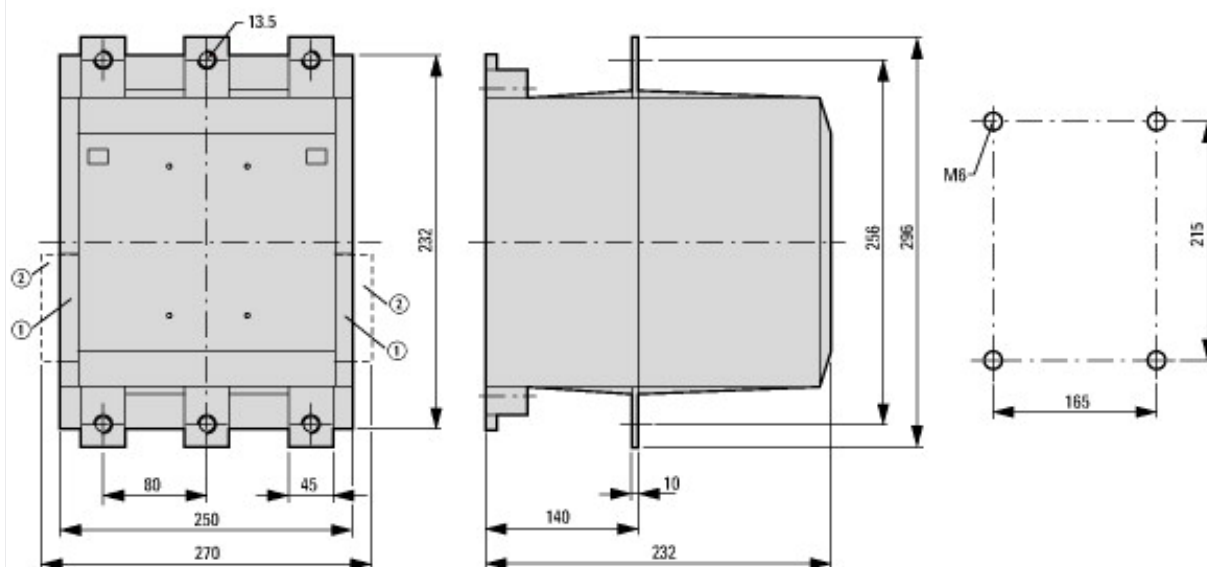

- ① DILM820-XHI11(V)-SI
- ② DILM820-XHI11-SA

Additional product information (links)

IL03407023Z (AWA2100-1697) Contactors >170 A

IL03407023Z (AWA2100-1697) Contactors >170 A ftp://ftp.moeller.net/DOCUMENTATION/AWA_INSTRUCTIONS/IL03407023Z2011_11.pdf

UL/CSA: Approved rating data <http://de.ecat.moeller.net/flip-cat/?edition=HPLTE&startpage=5.84>

UL/CSA: UL/CSA: Short Circuit Current Rating (SCCR) <http://de.ecat.moeller.net/flip-cat/?edition=HPLTE&startpage=5.86>

Switchgear of Power Factor Correction Systems http://www.moeller.net/binary/ver_techpapers/ver934en.pdf

X-Start - Modern Switching Installations Efficiently Fitted and Wired Securely http://www.moeller.net/binary/ver_techpapers/ver938en.pdf

Mirror Contacts for Highly-Reliable Information Relating to Safety-Related Control Functions http://www.moeller.net/binary/ver_techpapers/ver944en.pdf

Effect of the Cable Capacitance of Long Control Cables on the Actuation of Contactors http://www.moeller.net/binary/ver_techpapers/ver949en.pdf

Motor starters and "Special Purpose Ratings" for the North American market http://www.moeller.net/binary/ver_techpapers/ver953en.pdf

Switchgear for Luminaires http://www.moeller.net/binary/ver_techpapers/ver955en.pdf

Standard Compliant and Functionally Safe Engineering Design with Mechanical Auxiliary Contacts http://www.moeller.net/binary/ver_techpapers/ver956en.pdf

The Interaction of Contactors with PLCs http://www.moeller.net/binary/ver_techpapers/ver957en.pdf

Busbar Component Adapters for modern Industrial control panels http://www.moeller.net/binary/ver_techpapers/ver960en.pdf