

SPS range - Safety power supplies



The new range of EN 54-4 certified safety power supplies offer a compact, robust and versatile power solution to installers, allowing them to safely power fire detection and signaling systems in small to large installations.

The compact and discrete design allows for these power supplies to be installed in public places.

Comprehensive yet simple LED status indicators on the front of the unit help installers, commissioners and maintainers assess the status of the unit.

Features

- Compact design
- High useable current output
- Robust and resilient
- Clear LED status indicators

Benefits

- Easy to install and doesn't take up valuable space in a building
- Reduced number of power supplies installed in a system
- Product reliability and suitability for a variety of environments
- Assess status and capacity of unit efficiently

Specifier's guide

4.4 Ancillaries

Technical specification

| Code | SPS-2423 | SPS-2433 | SPS-2453 |
|------------------------------------|------------------------|------------------------|------------------------|
| Reference | SPS-24V-1A5/BNS | SPS-24V-2A5/BNS | SPS-24V-4A5/BNS |
| Standards | EN54-4 (A2) EN12101-10 | EN54-4 (A2) EN12101-10 | EN54-4 (A2) EN12101-10 |
| Output current (max.) | 1.5 | 2.5 | 4.5 |
| Output Voltage | 27.5 | 27.5 | 27.5 |
| Mains Voltage | 230 | 230 | 230 |
| Mains frequency | 50Hz | 50Hz | 50Hz |
| Number of protected outputs | 2 | 2 | 2 |
| Battery capacity | 4Ah | 7Ah | 17Ah |
| Transition time mains to battery | Instant | Instant | Instant |
| Door lock method | Screws | Screws | Screws |
| Charger fault relay | 1A/24V (NO/NC) | 1A/24V (NO/NC) | 1A/24V (NO/NC) |
| Battery resistor selector (switch) | Yes | Yes | Yes |
| Remote temperature probe | Yes | Yes | Yes |
| Temperature | -5°C/+40°C | -5°C/+40°C | -5°C/+40°C |
| IP | IP30 | IP30 | IP30 |

Installation

1. Enclosure is designed for wall mounting
2. 4 x 20mm knockouts are provided for cable entry at the rear of the enclosure
3. Outputs are protected by electronic circuit breakers

System functionality

1. SPS range power supplies provide outputs between 2.3A and 5.3A (including charging current)
2. Output available current (excluding charging current) from 1.5 to 4.5A
3. To enable batteries to be charged correctly, maximum continuous external load should not exceed the values displayed in the table above
4. LED indicators are provided to signify:
 - Power on (Green)
 - General fault (Yellow)
 - Mains fault (Yellow)
 - Charge fault (Yellow)
 - Battery resistance level (Blue or Yellow)

Dimensions

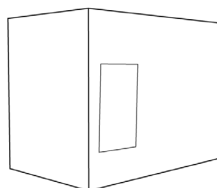

| H (mm) | W (mm) | D (mm) |
|--------|--------|--------|
| 220 | 300 | 175 |

Catalogue numbers

| Description | Code | Reference |
|--|----------|-----------------|
| Safety power supply 24V / 1.5A - EN54-4 certified - Batteries not supplied | SPS-2423 | SPS-24V-1A5/BNS |
| Safety power supply 24V / 2.5A - EN54-4 certified - Batteries not supplied | SPS-2433 | SPS-24V-2A5/BNS |
| Safety power supply 24V / 4.5A - EN54-4 certified - Batteries not supplied | SPS-2453 | SPS-24V-4A5/BNS |

Safety Power Supply

SPS-24V-1A5/BNS (SPS-2423)

SPS-24V-2A5/BNS (SPS-2433)

SPS-24V-4A5/BNS (SPS-2453)

Installation Manual

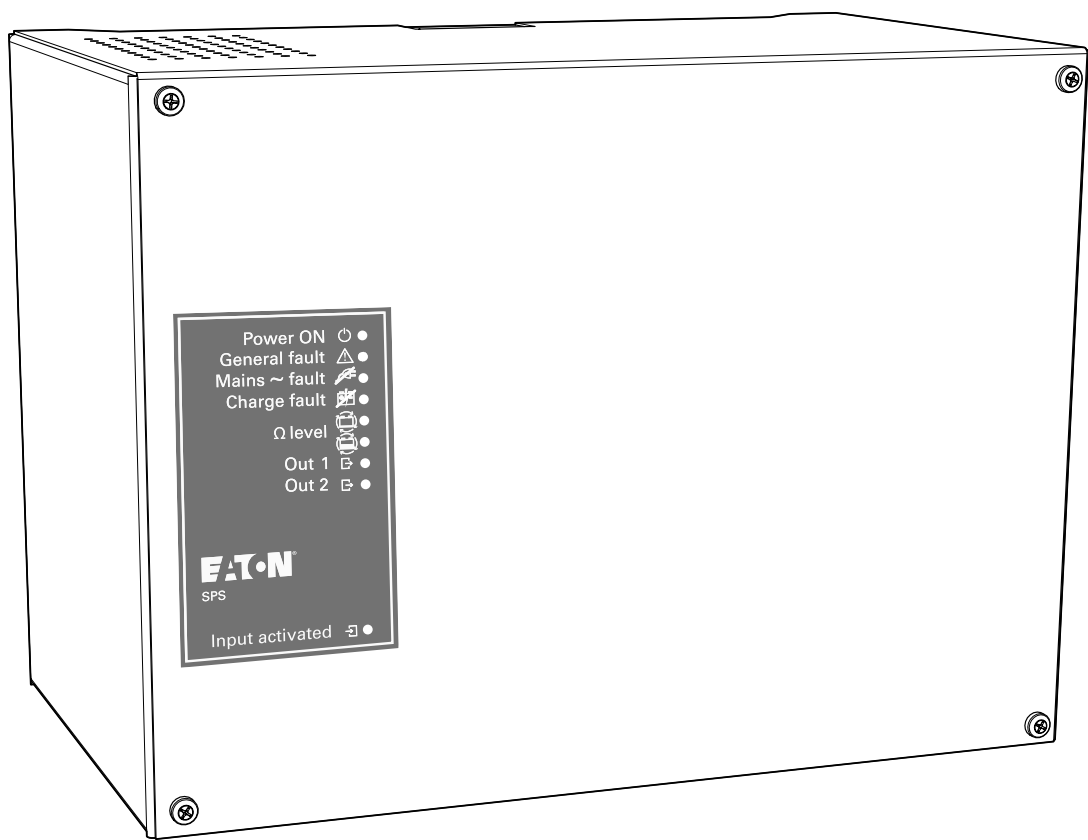

EATON

Powering Business Worldwide

Contents

Contents

| | |
|---|-----------|
| 1. INSTRUCTIONS – ENGLISH..... | 3 |
| 1.1 Important Instructions..... | 3 |
| 1.2 Operation / LED Description..... | 4 |
| 1.3 Technical Features..... | 5 |
| 2. INSTRUCTIONS – FRANÇAIS..... | 6 |
| 2.1 Instructions Importantes..... | 6 |
| 2.2 Fonctionnement / Description des voyants..... | 7 |
| 2.3 Caractéristiques techniques principales..... | 8 |
| 3. ISTRUZIONI – ITALIANO..... | 9 |
| 3.1 Istruzioni Importanti..... | 9 |
| 3.2 Funzionamento / Descrizione LED..... | 10 |
| 3.3 Caratteristiche tecniche..... | 11 |
| 4. HINWEISE – DEUTSCH..... | 12 |
| 4.1 Wichtige Hinweise..... | 12 |
| 4.2 Betrieb / LED Anzeigen..... | 13 |
| 4.3 Technische Merkmale..... | 14 |
| 5. INSTRUKCJE – POLSKI..... | 15 |
| 5.1 Wazne Instrukcje..... | 15 |
| 5.2 Praca / opis diod..... | 16 |
| 5.3 Wła ciwo ci techniczne..... | 17 |
| 6. INSTRUÇÕES – PORTUGUÊS..... | 18 |
| 6.1 Instruções Importantes..... | 18 |
| 6.2 Funcionamento / Descrição dos LEDs..... | 19 |
| 6.3 Características Técnicas..... | 20 |
| 7. INSTRUCTIES – NEDERLANDS..... | 21 |
| 7.1 Belangrijke Instructies..... | 21 |
| 7.2 Bediening / LED-functies..... | 22 |
| 7.3 Technische gegevens..... | 23 |
| 8. INSTALLATION AND MAINTENANCE..... | 24 |
| 8. INSTALLATION ET MAINTENANCE..... | 24 |
| 8. INSTALLAZIONE E MANUTENZIONE..... | 24 |
| 8. INSTALLATION UND WARTUNG..... | 24 |
| 8. INSTALACJA I KONSERWACJA..... | 24 |
| 8. INSTALAÇÃO E MANUTENÇÃO..... | 24 |
| 8. INSTALLATIE EN ONDERHOUD..... | 24 |
| 9. AUTONOMY..... | 34 |
| 10. NOTES..... | 35 |

1.1 Important Instructions

IMPORTANT - SAFETY

Read this manual carefully and in its entirety before any technical intervention on the device.

The operation must only be performed by qualified personnel.

Installation and commissioning of product must be done by following sequence describe below. Order of steps is important and must be described.

Cut mains off before any intervention on device.

The power supply unit must be provided upstream with:

- a bipolar disconnecting device;
- a circuit breaker: 4 A - D Curve.

The device must be carried carefully and stored in proper conditions (humidity and temperature).

The Installer must check that device has not been damaged during transport and installation. A damaged product may cause serious injury. A damaged product must never be connected to the mains.

The device must never be connected to the mains if it is not properly fixed to the wall with its housing properly connected to protective earth (see first step of installation).

Replacing the original battery with a battery of incorrect type may result in an explosion hazard. Used batteries must be disposed of in compliance with recycling requirements.

This device is a class A device. In a residential environment, this device can cause radio frequency interference. In this case, the user may take appropriate measures.

Use 4 screws with a diameter up to 5 mm. Plugs and screws must be adapted to type of wall. Each fixing plugs/screws must support a minimum weight of 20 kg (80 kg split on each fixing screw).



Electrical shock risk symbol



Protective earth terminal

Typical applications

The SPS is a two output-24V dc battery backed power supply. It is a high efficiency switching power supply; protected from overload and short circuits.

It is specifically recommended as an auxiliary power supply unit for fire detection system components, such as electromagnets, notification devices, etc.

Conformity to standards



DoP Nos:
SPS-24-1A5/BNS: SPS1A5CE
SPS-24-2A5/BNS: SPS2A5CE
SPS-24-4A5/BNS: SPS4A5CE

This device complies with the following standards:











- EN 54-4: 1997 / A1: 2003 / A2: 2005;
- EN12101-10:2005 class A Env. class 1.

Recycling Instructions

Wasted electrical products should not be disposed of with household waste. Please recycle where facilities exist. Check with your local authority or retailer for recycling advice.



1.2 Operation / LEDs Description

| | Colour | Status |
|--|----------------|--|
| Power ON  | Green | Mains and/or batteries are present. |
| General fault  | Yellow | There is at least one fault on the SPS. Then the general fault relay is also activated. |
| Mains ~ fault  | Yellow | Mains is not present or its value is out of range. |
| Charge fault  | Yellow | <ul style="list-style-type: none"> Batteries are not present; or Batteries voltage is out of range; or There is a charge failure; or The batteries resistance level exceeded the threshold. |
| Ω level  | Yellow or Blue | Batteries resistance level (see note below): <ul style="list-style-type: none">  Low  Medium  High |
| Out 1  | | |
| Out 2  | | |
| EN 54-4 : A2 EN 12101-10 EATON SPS | Green | <ul style="list-style-type: none"> Both LEDs flashing: default threshold reached. A battery fault is activated. ON: output 1/2 is power-supplied. OFF: output 1/2 is not power-supplied. Flashing: output 1/2 in fault mode (ex.: short-circuit or overload). |
| Input activated  | Green | ON when the input is activated. Then output 1 is deactivated (output 2 remains activated). This deactivation can be delayed of 10 minutes depending on switch configuration. |

General fault relay The general fault relay is activated when there is at least one fault on the SPS.

User input This input is used to activate or deactivate remotely the output 1. Input is activated when a short-circuit is applied between two terminal pins. Then output 1 is deactivated (output 2 remains activated). This deactivation can be delayed by 10 minutes depending on switch configuration. See 2 - Connection. Example 1: This input can be used to deactivate output 1 during an alarm using a relay on the fire panel. Example 2: This input can be used to deactivate output 1 during mains failure using the mains fault relay on the fire panel. It will maintain battery capacity for the output 2.

Self resetting electronic fuse Both outputs are protected by an electronic circuit breaker. In case of overload or short circuit on an output, the voltage of this output is switched off. In this case the output LED blinks. Every 30 seconds the power supply tries to power on voltage. If overload is no longer present the voltage is resumed, else the output remains switched off until the next try.

NOTE : this functionality is activated only when switch N°5 is in the ON position. If not activated, the internal resistance check is performed, however the LEDs remain off.

Control of internal resistor of battery pack The power supply checks periodically the internal resistor of battery and displays the result on front LEDs. No LEDs turned off means low resistance. Two LEDs turned on means a high resistance. If two LEDs are blinking then the threshold is exceeded and a battery fault is activated. In this condition the battery is not able to supply high current within the voltage range. Battery wires should also be checked in case of high internal resistor.

1.3 Technical Features

IMPORTANT

Both outputs are electronically protected.

| | SPS-24V-1A5/BNS | SPS-24V-2A5/BNS | SPS-24V-4A5/BNS | |
|---|---|---------------------------------------|--------------------------|-----------------------|
| Network input | Voltage (V_{in}) | 230 V ac (-15 % ; +10 %) | | |
| | Frequency (F_{in}) | 50 Hz | | |
| | Current max.RMS (@195 V)(I_{inmax}) | 1.2 A | 1.5 A | 2 A |
| | Class (EN12101-10) | I | | |
| | Neutral system | TT, IT | | |
| | Circuit breaker | Radial leaded time delay fuse (2.5 A) | | |
| Output | Voltage "Out 1" Voltage "Out2" @ $V_{in} > 195$ V | 27.5 V (+/-0.5 V) | 27.5 V (+/-0.5 V) | 27.5 V (+/-0.5 V) |
| | Voltage "Out 1" Voltage "Out2" @ $V_{in} > 0$ V | 20.4 V to 27 V | 20.4 V to 27 V | 20.4 V to 27 V |
| | Max current "Out 1" Max current "Out 2" | 1.5 A | 2.5 A | 4.5 A |
| | Max Current "Out 1+Out 2" $I_{maxa}=I_{maxb}$ | 1.5 A | 2.5 A | 4.5 A |
| | Min current "Out 1" Min current "Out 2" | | 0 A | |
| | Residual ripple voltage "Out 1"& "Out 2" | | <1 % | |
| | Relay | Max switching current | 1 A @ 24 V | |
| | | Max switching voltage | 120 V dc / 50 V ac (ELV) | |
| | Batteries/charger | Charger current max | 1.0 A (+/-0.1 A) | |
| | | Final voltage | 21 V | |
| Cut-off voltage | | 21.0 V (+/-0.6 V) | | |
| Battery capacity | | 4 Ah | 7 Ah | 17 Ah |
| Internal impedance max R_{int} max | | 0.8 Ω | 0.6 Ω | 0.6 Ω |
| Recommended bat- teries | | Yuasa NP4-12 | Yuasa NP7-12 | Yuasa NP17-12 |
| Circuit breaker (F1) | | Fuse 5x20 - 2 A (F) | Fuse 5x20 - 3.15 A (F) | Fuse 5x20 - 6.3 A (F) |
| Switching delay (EN12101-10) | | | 0 s | |
| Environment | Dimension (l x h x d) | 300x220x175 (mm) | | |
| | Operating temperature | -5 °C to +40 °C | | |
| | Relative humidity | 20 to 95 % | | |
| | Altitude | <2000 m | | |
| | IP | 30 | | |
| | Storage temperature | -10°C to +50°C | | |
| Environment class (EN 12101-10) | Class I | | | |

2.1 Instructions Importantes

IMPORTANT - SÉCURITÉ

Lisez attentivement cette notice dans son intégralité avant toute intervention technique sur l'appareil.

L'opération doit être effectuée uniquement par du personnel qualifié.

L'installation et la mise en service du produit doivent être effectuées dans l'ordre décrit ci-après. L'ordre des étapes est important et doit être respecté.

Coupez le secteur avant toute intervention sur l'appareil.

L'équipement doit posséder en amont :

- un sectionneur bipolaire,
- un coupe-circuit : 4 A - courbe D.

L'appareil doit être transporté avec soin et stocké dans de bonnes conditions (humidité et température).

L'installateur doit vérifier que l'appareil n'a pas été endommagé durant le transport et l'installation. Un appareil endommagé peut provoquer de graves blessures. Un appareil endommagé ne doit jamais être raccordé au secteur.

L'appareil ne doit jamais être raccordé au secteur s'il n'est pas correctement fixé au mur, avec son boîtier correctement raccordé à la terre (voir la première étape de l'installation).

Remplacer la batterie d'origine par une batterie de type incorrect peut provoquer un risque d'explosion. Les batteries usagées doivent être jetées conformément aux instructions de recyclage.

Il s'agit d'un appareil de classe A. Dans un environnement résidentiel, cet appareil peut créer des interférences dans les fréquences radio. Le cas échéant, l'utilisateur peut prendre des mesures adéquates.

Utilisez 4 vis de 5 mm de diamètre. Les chevilles et les vis doivent être adaptées au type de mur. Chaque cheville/vis de fixation doit supporter un poids minimum de 20 kg (le poids total de 80 kg est réparti sur chaque vis de fixation).



Risque de choc électrique



Borne à la terre principale.

Types d'application

La SPS est une alimentation électrique de sécurité avec deux sorties en 24V et un jeu de batteries. C'est une alimentation à découpage à haute efficacité protégée contre les sur-intensités et les courts-circuits.

Elle est particulièrement recommandée en tant qu'alimentation auxiliaire pour les périphériques utilisés dans les systèmes de détection d'incendies tels que les ventouses magnétiques, électro-aimants, les diffuseurs lumineux ou sonores, dispositifs de notification, etc.

Conformité aux normes



DoP Nos :

SPS-24-1A5/BNS: SPS1A5CE

SPS-24-2A5/BNS: SPS2A5CE

SPS-24-4A5/BNS: SPS4A5CE











- EN 54-4: 1997 / A1: 2003 / A2: 2005 ;
- EN12101-10:2006 class A Env. class 1.

Consignes de recyclage

Les produits électriques usagés ne doivent pas être jetés avec les déchets domestiques. Merci de les recycler aux endroits appropriés. Demandez conseil à vos autorités locales ou à votre revendeur pour le recyclage.



2.2 Fonctionnement / Description des voyants

| | Couleur | Statut |
|---|----------------|--|
| Power ON  | Vert | Le secteur et /ou les batteries sont présents. |
| General fault  | Jaune | Il y a au moins un défaut sur l'alimentation SPS. Le relais de défaut général est alors également activé. |
| Mains ~ fault  | Jaune | Le secteur n'est pas présent ou sa valeur dépasse les tolérances acceptées. |
| Charge fault  | Jaune | |
| Ω level  | Jaune | |
| Out 1  | Jaune ou Bleue | <ul style="list-style-type: none"> Les batteries ne sont pas présentes ; ou La tension des batteries dépasse les tolérances acceptées ; ou Il y a un défaut de charge ; ou Le niveau de résistance des batteries a dépassé le seuil. |
| Out 2  | | |
| EN 54-4 : A2 EN 12101-10 | | |
| EATON SPS | | |
| Input activated  | Vert | <ul style="list-style-type: none"> Niveau de résistance des batteries (voir Note ci-dessous) : <ul style="list-style-type: none">  Faible  Moyen  Élevé Les deux voyants clignotent : le seuil de défaut est atteint. Un défaut batterie est activé. ON : la sortie 1/2 est alimentée. OFF : la sortie 1/2 n'est pas alimentée. Clignotant : la sortie 1/2 est en mode défaut (ex. : court-circuit ou surintensité). |
| | Vert | Allumé lorsque l'entrée est activée. La sortie 1 est alors désactivée (la sortie 2 reste activée). Cette désactivation peut être temporisée de 10 minutes selon la configuration du switch. |

Relais de défaut général

Le relais de défaut général est activé quand il y a au moins un défaut sur l'alimentation SPS.

Entrée utilisateur

Cette entrée sert à activer ou à désactiver la sortie 1 à distance. L'entrée est activée lorsqu'un court-circuit a lieu entre deux broches de raccordement.

La sortie 1 est alors désactivée (la sortie 2 reste activée). Cette désactivation peut être temporisée de 10 minutes selon la configuration du switch.

Voir 2 - Raccordement.

Exemple 1 : Cette entrée peut servir à désactiver la sortie 1 pendant une alerte en utilisant un relais de la centrale incendie.

Exemple 2 : Cette entrée peut servir à désactiver la sortie 1 pendant un défaut secteur en utilisant le relais de défaut secteur sur la centrale incendie. Cela maintiendra la capacité des batteries pour la sortie 2.

Fusible électronique à réarmement automatique

Les deux sorties sont protégées par un coupe-circuit électronique. En cas de sur-intensité ou de court-circuit sur une sortie, la tension de cette sortie est coupée. Dans ce cas, le voyant de sortie clignote. Toutes les 30 secondes, l'alimentation essaie de remettre la tension. S'il n'y a plus de surcharge, la tension revient. Sinon, la sortie reste coupée jusqu'à la tentative suivante.

Contrôle de la résistance interne de la batterie

L'alimentation vérifie régulièrement la résistance interne de la batterie et affiche le résultat sur les voyants en face avant. Si tous les voyants sont éteints, la résistance est faible. Si les deux voyants sont allumés, la résistance est élevée. Si les deux voyants clignotent, le seuil est alors dépassé et un défaut batterie est activé. Dans ce cas, la batterie n'est pas en mesure de délivrer une tension de sortie dans les plages de tolérance. Les câbles de la batterie doivent également être vérifiés en cas de résistance interne élevée.

NOTE : Cette fonction est active uniquement si le switch n°5 est placé en position ON. Dans le cas contraire le test est réalisé mais les Leds restent éteintes.

2.3 Caractéristiques techniques principales

IMPORTANT

Les deux sorties sont protégées électroniquement.

| | SPS-24V-1A5/BNS | SPS-24V-2A5/BNS | SPS-24V-4A5/BNS | |
|---|---|---------------------------|---------------------------|--------------------------|
| Entrée secteur | Tension (V_{in}) | 230 V ac (-15 % ; +10 %) | | |
| | Fréquence (F_{in}) | 50 Hz | | |
| | Courant max. RMS (@195 V)(I_{inmax}) | 1,2 A | 1,5 A | 2 A |
| | Classe (EN12101-10) | I | | |
| | Système neutre Fusible | TT, IT | | |
| | Coupe Circuit | Fusible temporisé (2,5 A) | | |
| Sortie | Tension « sortie 1 » Tension « sortie 2 » @ $V_{in} > 195$ V | 27,5 V (+/-0,5 V) | 27,5 V (+/-0,5 V) | 27,5 V (+/-0,5 V) |
| | Tension « sortie 1 » Tension « sortie 2 » @ $V_{in} > 0$ V | 20,4 V to 27 V | 20,4 V to 27 V | 20,4 V to 27 V |
| | Courant max « sortie 1 » Courant max « sortie 2 » | 1,5 A | 2,5 A | 4,5 A |
| | Courant max « sortie 1 + sortie 2 » $I_{maxa} = I_{maxb}$ | 1,5 A | 2,5 A | 4,5 A |
| | Courant min « sortie 1 » Courant min « sortie 2 » | | 0 A | |
| | Tension d'ondulation résiduelle « sortie 1 » et « sortie 2 » | | <1 % | |
| | Relais | Courant de coupure max | 1 A à 24 V | |
| | | Tension de coupure max | 120 V DC / 50 V AC (TBT) | |
| | Batteries/chargeur | Courant de chargeur max | 1,0 A (+/-0,1 A) | |
| | | Tension finale | 21 V | |
| Tension de coupure | | 21,0 V (+/-0,6 V) | | |
| Capacité de la batterie | | 4 Ah | 7 Ah | 17 Ah |
| Impédance interne max. R_{int} max | | 0,8 Ω | 0,6 Ω | 0,6 Ω |
| Batteries recommandées | | Yuasa NP4-12 | Yuasa NP7-12 | Yuasa NP17-12 |
| Coupe-circuit (F1) | | Fusible 5x20 - 2 A (F) | Fusible 5x20 - 3,15 A (F) | Fusible 5x20 - 6,3 A (F) |
| Retard de commutation (EN12101-10) | | 0s | | |
| Environnement | Dimensions (LxHxP) | 300x220x175 (mm) | | |
| | Température de fonctionnement | -5 °C à +40 °C | | |
| | Humidité relative (max.) | 20 to 95 % | | |
| | Altitude | <2000 m | | |
| | IP | 30 | | |
| | Température de stockage | -10 °C à +50 °C | | |
| | Classe environnementale (EN 12101-10) | Classe I | | |

3.1 Istruzioni Importanti

IMPORTANTE - SICUREZZA

Leggere attentamente l'intero manuale prima di qualsiasi intervento tecnico sul dispositivo.

Qualsiasi operazione deve essere eseguita esclusivamente da personale qualificato.

L'installazione e la messa in funzione del prodotto devono essere effettuate in conformità alla procedura descritta di seguito. È importante rispettare l'ordine di esecuzione dei passaggi indicati.

Scollegare la rete elettrica prima di qualsiasi intervento sul dispositivo.

L'unità di alimentazione deve essere provvista a monte di:

- un dispositivo di sezionamento bipolare;
- un interruttore: 4A - Curva D.

Il dispositivo deve essere trasportato con cautela e deve essere conservato in condizioni di umidità e temperatura adeguate.

L'installatore deve verificare che il dispositivo non abbia subito danni durante il trasporto e l'installazione. Un prodotto danneggiato potrebbe causare lesioni gravi. Non collegare mai un prodotto danneggiato alla rete elettrica.

Non collegare mai il dispositivo alla rete elettrica nel caso in cui non sia fissato correttamente alla parete e il relativo alloggiamento non sia collegato correttamente a una messa a terra di protezione (vedere la prima operazione di installazione).

Non sostituire la batteria originale con un modello di batteria errato poiché ciò potrebbe causare un'esplosione. Le batterie utilizzate devono essere smaltite in conformità con le normative vigenti.

Questo dispositivo è un dispositivo di classe A. In una zona residenziale, il dispositivo potrebbe causare interferenze di radio frequenze. In questo caso, l'utente adotterà le misure che riterrà più opportune.

Utilizzare 4 viti di un diametro massimo di 5 mm. I connettori e le viti devono essere conformi al tipo di parete in uso. Ogni connettore/vite di fissaggio deve poter sostenere un peso minimo di 20 kg (80 kg suddivisi su ogni vite di fissaggio).



Simbolo di rischio di scosse elettriche



Terminale di protezione di messa a terra

Applicazioni tipiche

Il dispositivo SPS è un gruppo di alimentazione con due uscite a 24 Vcc dotato di due batterie in tampone. Si tratta di un gruppo di alimentazione switching ad alta efficienza, provvisto di sistema di protezione da sovraccarichi e cortocircuiti.

Viene particolarmente consigliato come unità di alimentazione ausiliaria per componenti di sistemi di rilevazione degli incendi, come ad esempio gli elettromagneti, i dispositivi di notifica, ecc.

Conformità alle normative



DoP Nos:

SPS-24-1A5/BNS: SPS1A5CE

SPS-24-2A5/BNS: SPS2A5CE

SPS-24-4A5/BNS: SPS4A5CE

Questo dispositivo è conforme alle seguenti normative:











- EN54-4: 1997/A1:2003/A2:2006;
- EN12101-10:2005 classe ambientale A

Istruzioni per lo smaltimento

I prodotti elettrici di scarto non devono essere smaltiti unitamente ai rifiuti domestici ma presso le strutture preposte. Rivolgersi al proprio ente locale o al rivenditore per consigli sullo smaltimento.



3.2 Funzionamento / Descrizione LED

| | Colore | Stato |
|---|--------------|---|
| Power ON  | Verde | Rete di alimentazione e/o batterie presenti. |
| General fault  | Giallo | Si è verificato almeno un guasto nell'SPS. È stato attivato anche il relè di guasto generale. |
| Mains ~ fault  | Giallo | La rete di alimentazione non è presente o i suoi valori non rientrano nell'intervallo di funzionamento. |
| Charge fault  | Giallo | <ul style="list-style-type: none"> Le batterie non sono presenti; oppure La tensione delle batterie non rientra nell'intervallo di funzionamento; oppure Si è verificato un errore di carica batteria; oppure Il livello di resistenza delle batterie supera il limite massimo. |
| Ω level  | Giallo o Blu | Livello di resistenza delle batterie (vedere la nota sottostante): <ul style="list-style-type: none">  Basso  Medio  Alto |
| Out 1  | | |
| Out 2  | Verde | <ul style="list-style-type: none"> ACCESO: l'uscita 1/2 risulta alimentata SPENTO: l'uscita 1/2 non risulta alimentata Lampeggiante: l'uscita 1/2 si trova in modalità di guasto (ad esempio: cortocircuito o sovraccarico). |
| EN 54-4 : A2 EN 12101-10 | | |
| EATON SPS | | |
| Input activated  | Verde | ACCESO quando l'ingresso risulta attivato. L'uscita 1 viene disattivata (l'uscita 2 rimane attiva). Questa disattivazione può essere ritardata di 10 minuti a seconda della configurazione dell'ingresso. |

| | |
|--|--|
| Relè di guasto generale | Il relè di guasto generale viene attivato quando si è verificato almeno un guasto nell'SPS. |
| Ingresso utente | <p>Questo ingresso viene utilizzato per attivare o disattivare l'uscita 1 a distanza. L'ingresso viene attivato quando viene applicato un cortocircuito tra i due morsetti.</p> <p>Quindi l'uscita 1 viene disattivata (l'uscita 2 rimane attiva). Questa disattivazione può essere ritardata di 10 minuti a seconda della configurazione del commutatore.</p> <p>Vedere 2 - Collegamento.</p> <p>Esempio 1: questo ingresso può essere utilizzato per disattivare l'uscita 1 durante un allarme utilizzando il relè posto sulla centrale o modulo di uscita.</p> <p>Esempio 2: questo ingresso può essere utilizzato per disattivare l'uscita 1 durante un guasto alla rete di alimentazione usando il relè di guasto posto sulla centrale. La capacità delle batterie verrà mantenuta per l'uscita 2.</p> |
| Fusibile elettronico con autoripristino | Entrambe le uscite sono protette da un circuito di interruzione elettronico. In caso di sovraccarico o cortocircuito su un'uscita, la tensione di tale uscita verrà disattivata. In questo caso, il LED relativo all'uscita lampeggerà. Ogni 30 secondi il sistema di alimentazione tenterà di attivare la tensione. Se non si è verificato un sovraccarico, la tensione viene riattivata, altrimenti l'uscita rimarrà disattivata fino al tentativo successivo. |
| Controllo della resistenza interna della batteria | <p>Il sistema di alimentazione verifica periodicamente la resistenza interna della batteria e visualizza il risultato sui LED frontali. Se i due LED risultano spenti, significa bassa resistenza. Se i due LED risultano accesi, significa alta resistenza. Se due LED lampeggiano, significa che è stato superato il limite massimo e che si è verificato un guasto della batteria. In queste condizioni, la batteria non è in grado di fornire una corrente elevata compresa nell'intervallo di tensione. In caso di elevata resistenza interna, occorre verificare anche i cavi della batteria.</p> <p>NOTA: questa funzione è attivata solamente quando lo switch N°5 è in posizione "ON". Se non attivata, il controllo della resistenza interna viene eseguito, ma i LED rimangono spenti.</p> |

3.3 Caratteristiche tecniche



IMPORTANTE

Entrambe le uscite sono protette elettronicamente

| | SPS-24V-1A5/BNS | SPS-24V-2A5/BNS | SPS-24V-4A5/BNS | |
|----------------------------|--|---|--------------------------|-------------------|
| Ingresso di rete | Tensione (V_{in}) | 230 V ca (-15 % ;+10 %) | | |
| | Frequenza (F_{in}) | 50 Hz | | |
| | RMS di corrente massimo (@195 V)(I_{inmax}) | 1,2 A | 1,5 A | 2 A |
| | Classe (EN12101-10) | I | | |
| | Sistema neutro | TT, IT | | |
| | Fusibile | Fusibile radiale ad azione ritardata(2,5 A) | | |
| Uscita | Tensione "Uscita 1" Tensione "Uscita 2" a $V_{in} > 195$ V | 27,5 V (+/-0,5 V) | 27,5 V (+/-0,5 V) | 27,5 V (+/-0,5 V) |
| | Tensione "Uscita 1" Tensione "Uscita 2" a $V_{in} > 0$ V | Da 20,4 V to 27 V | Da 20,4 V to 27 V | Da 20,4 V to 27 V |
| | Corrente massima "Uscita 1" Corrente massima "Uscita 2" | 1,5 A | 2,5 A | 4,5 A |
| | Corrente massima "Uscita 1+Uscita 2" $I_{maxa}=I_{maxb}$ | 1,5 A | 2,5 A | 4,5 A |
| | Corrente minima "Uscita 1" Corrente minima "Uscita 2" | 0 A | | |
| | Tensione di Ripple residua "Uscita 1" e "Uscita 2" | <1 % | | |
| | Relè | Corrente massima di commutazione | 1 A a 24 V | |
| | | Tensione massima di commutazione | 120 V cc / 50 V ac (ELV) | |
| Batterie/caricatore | Corrente massima di carica batteria | 1,0 A (+/-0,1 A) | | |
| | Tensione finale | 21 V | | |
| | Tensione di sgancio batteria | 21,0 V (+/-0,6 V) | | |
| | Capacità della batteria | 4 Ah | 7 Ah | 17 Ah |
| | Massima impedenza interna R_{intmax} | 0,8 Ω | 0,6 Ω | 0,6 Ω |
| | Batterie consigliate | Yuasa NP4-12 | Yuasa NP7-12 | Yuasa NP17-12 |
| | Fusibile 5x20 (F1) | F 2 A | F 3,15 A | F 6,3 A |
| | Ritardo di commutazione (EN12101-10) | 0 s | | |
| Ambiente | Dimensione (LxHxP) | 300x220x175 (mm) | | |
| | Temperatura di esercizio | Da -5 °C to +40 °C | | |
| | Umidità relativa | Da 20 to 95 % | | |
| | Altitudine | <2000 m | | |
| | IP | 30 | | |
| | Temperatura di stoccaggio Classe ambientale (EN 12101-10) | Da -10 °C a +50 °C Classe I | | |

4.1 Wichtige Hinweise

WICHTIG - SICHERHEIT

Lesen Sie dieses Handbuch sorgfältig und vollständig, bevor Sie Arbeiten am Gerät beginnen.

Alle Arbeiten dürfen nur von qualifiziertem Fachpersonal durchgeführt werden.

Installation und Einstellung des Gerätes dürfen nur entsprechend der folgenden Anleitung ausgeführt werden. Die Reihenfolge der Schritte bei der Abarbeitung ist unbedingt einzuhalten. Schalten Sie die Netzversorgung des Gerätes frei, bevor Sie das Gerät öffnen.

Die Zuleitung der Netzspannung muß ausgerüstet werden mit:

- einer 2-poligen Trenneinrichtung;
- einem Schutzschalter: 4 A - D-Kurve.

Das Gerät muss sorgfältig behandelt und bestimmungsgemäß (Luftfeuchtigkeit und Temperatur) gelagert werden.

Der Errichter muss prüfen, dass das Gerät bei Transport und Installation nicht beschädigt wurde. Ein beschädigtes Produkt kann zu schweren Verletzungen führen. Ein beschädigtes Gerät darf nicht an das Stromnetz angeschlossen werden.

Das Gerät darf nie an das Stromnetz angeschlossen werden, sofern es ist nicht korrekt an der Wand montiert und das Gehäuse an das Potential der Schutzerde angeschlossen wurde (siehe ersten Schritt der Installation).

Ersetzen des originalen Akkus durch einen Akku des falschen Typs kann zu Explosionsgefahr führen. Gebrauchte Batterien müssen in Übereinstimmung mit geltenden Richtlinien zur Wiederverwertung entsorgt werden.

Dieses Gerät ist ein Gerät der Klasse A. In Wohngebäuden kann dieses Gerät Hochfrequenz-Störungen verursachen. Der Benutzer soll in diesem Fall geeignete Maßnahmen ergreifen. Die Befestigung erfolgt mit 4 Schrauben, Durchmesser bis 5 mm. Dübel und Schrauben müssen dem Befestigungsort angepasst sein. Jede/r Dübel/Schraube muss ein Mindestgewicht von 20 kg (80 kg aufgeteilt auf alle 4 Befestigungsschrauben) tragen können.



Symbol für Stromschlag-Gefahr



Erdanschluß

Typische Anwendungen

Die SPS ist eine batteriegepufferte Stromversorgung mit zwei Ausgängen-24V DC. Es ist ein Schaltnetzteil mit hohem Wirkungsgrad; geschützt gegen Überlast und Kurzschluss.

Es wird speziell zur Versorgung von Brandmelde-Systemkomponenten wie Elektromagneten, Signalgebern und ähnlichen Geräte empfohlen.

Normenkonformität



15

DoP Nos:

SPS-24-1A5/BNS: SPS1A5CE
SPS-24-2A5/BNS: SPS2A5CE
SPS-24-4A5/BNS: SPS4A5CE













- EN54-4: 1997/A1:2003/A2:2006;
- EN12101-10:2005 Klasse A Umkelklasse 1

Entsorgung / Wiederverwertung

Defekte elektrische Produkte sollten nicht mit dem Hausmüll entsorgt werden. Befolgen Sie die örtlichen Richtlinien der Behörden und entsorgen Sie die Geräte entsprechend.



4.2 Betrieb / LED Anzeigen

| | Grün | Status |
|---|----------------------|--|
| Power ON  | Grün (Betrieb) | Netzspannung oder Akkus in Funktion. |
| General fault  | Gelb (Sammelstörung) | Das Netzteil ist gestört. Das Sammelstörrelais ist aktiviert. |
| Mains ~ fault  | Gelb (Netzstörung) | Netzspannung ist nicht vorhanden oder Netzspannung außerhalb des gültigen Bereichs. |
| Charge fault  | Gelb (Ladestörung) | <ul style="list-style-type: none"> Batterien nicht angeschlossen; oder Batteriespannung fehlerhaft; oder Ladestörung; oder Innenwiderstand der Akkus fehlerhaft. |
| Ω level  | Gelb oder Blau | Innenwiderstand der Akkus (Siehe Hinweis unten): <ul style="list-style-type: none">  Niedrig  Mittel  Hoch |
| Out 1  | | |
| Out 2  | Grün (Ausgang 1/2) | <ul style="list-style-type: none"> Beide LEDs blinken: Innenwiderstand der Akkus fehlerhaft. Eine Ladestörung wird aktiviert AN: Ausgang 1/2 ist spannungsversorgt. AUS: Ausgang 1/2 ist spannungsfrei. Blinkt: Ausgang 1/2 gestört (z.B. Kurzschluß, Überlast). |
| EN 54-4 : A2 EN 12101-10 | Grün (Eingang aktiv) | AN wenn Eingang aktiviert. Ausgang 1 ist abgeschaltet (Ausgang 2 bleibt ein) Die Abschaltung Ausgang 2 kann bis zu 10 Minuten verzögert erfolgen, abhängig von der gewählten Konfiguration.. |
|  SPS | | |
| Input activated  | | |

| | |
|--|--|
| Sammelstörrelais | Das Sammelstörrelais wird durch die erste Störung des Gerätes aktiviert. |
| Eingang | <p>Wird dieser Eingang durch einen Schaltkontakt kurzgeschlossen, schaltet Ausgang 1 sofort ab.</p> <p>Ausgang 2 kann bis zu 10 Minuten verzögert abgeschaltet werden, abhängig von der programmierten Zeit.</p> <p>Siehe 2 - Anschluß</p> <p>Beispiel 1: Dieser Eingang kann verwendet werden, um Ausgang 1 während eines Alarms mit einem Kontakt der Brandmeldezentrale zu deaktivieren.</p> <p>Beispiel 2: Dieser Eingang kann verwendet werden, um Ausgang 1 bei Netzausfall über die Brandmeldezentrale zu deaktivieren. Die Batteriekapazität wird für Ausgang 2 reserviert.</p> |
| Elektronische Sicherungen | Beide Ausgänge werden durch elektronische Sicherungen geschützt. Bei Überlast oder Kurzschluß wird die Ausgangsspannung abgeschaltet. In diesem Fall blinkt die LED Ausgang 1/2. Alle 30 Sekunden wird der entsprechende Ausgang geprüft, sobald Überlast/Kurzschluß nicht mehr anliegen, wird die Spannung wieder eingeschaltet. |
| Überwachung des Innenwiderstandes der Batterien | <p>Das Netzteil prüft den Innenwiderstand der Batterien zyklisch und zeigt diesen mittels LED am Gerät an. Fehlende Batterien erzeugen zu niedrigen Widerstand (LEDs aus), beide LEDs werden bei zu hohem Widerstand aktiviert. Blinken beide, liegt der Wert außerhalb der Vorgaben, die Versorgung der angeschlossenen Geräte durch die Batterien ist nicht mehr sichergestellt. Bei hohem Widerstand sollten auch die Batterieanschlüsse und -kabel überprüft werden.</p> <p>HINWEIS: diese Funktion ist nur dann aktiviert, wenn sich Schalter Nr. 5 in der ON-Position befindet. Ist die Funktion deaktiviert, erfolgt die Prüfung des Innenwiderstandes ohne LED-Anzeige.</p> |

4.3 Technische Merkmale

WICHTIG
Beide Ausgänge werden elektronisch gesichert

| | SPS-24V-1A5/BNS | SPS-24V-2A5/BNS | SPS-24V-4A5/BNS | |
|----------------------------|--|--------------------------|-------------------|-------------------|
| Eingang Netz | Spannung (V_{in}) | 230 V ac (-15 % ; +10 %) | | |
| | Schlussspannung (F_{in}) | 21 V | | |
| | Ausgangsstrom max. RMS (@195 V)(I_{inmax}) | 1.2 A | 1.5 A | A |
| | Klasse (EN12101-10) | I | | |
| | Netzform (Schutzleiter) | TT, IT | | |
| | Absicherung | (2.5 A) | | |
| Ausgang | Spannung Ausgang 1 | 27.5 V (+/-0.5 V) | 27.5 V (+/-0.5 V) | 27.5 V (+/-0.5 V) |
| | Spannung Ausgang 2 @ $V_{in} > 195$ V | | | |
| | Spannung Ausgang 1 | 20.4 V to 27 V | 20.4 V to 27 V | 20.4 V to 27 V |
| | Spannung Ausgang 2 @ $V_{in} > 0$ V | | | |
| | Maximalstrom Ausgang 1 | 1.5 A | 2.5 A | 4.5 A |
| | Maximalstrom Ausgang 2 | | | |
| | Maximalstrom Ausg. 1 + 2 $I_{maxa}=I_{maxb}$ | 1.5 A | 2.5 A | 4.5 A |
| | Minimalstrom Ausgang 1 | | 0 A | |
| | Minimalstrom Ausgang 2" | | | |
| | Restwelligkeit Ausgang 1 + 2 | | <1 % | |
| Störrelais | Kontaktbelastung max. | 1 A @ 24 V DC | | |
| | Schaltspannung max. | 120 V DC / 50 V AC | | |
| Batterien/Ladekreis | Ladestrom max | 1.0 A (+/-0.1 A) | | |
| | Schlussspannung | 21 V | | |
| | Abschaltspannung | 21.0 V (+/-0.6 V) | | |
| | Batteriekapazität | 4 Ah | 7 Ah | 17 Ah |
| | Innenwiderstand | 0.8 Ω | 0.6 Ω | 0.6 Ω |
| | Akkusatz R_{int} max | | | |
| | Empfohlener Batterietyp | Yuasa NP4-12 | Yuasa NP7-12 | Yuasa NP17-12 |
| | Akkusicherung 5x20 (F1) | F 2 A | F 3.15 A | F 6.3 A |
| | Schaltverzögerung (EN12101-10) | | 0 s | |
| Umwelt | Abmessungen (LxBxT) | 300x220x175 (mm) | | |
| | Betriebstemperatur | -5 °C to +40 °C | | |
| | Relative Luftfeuchte | 20 to 95 % | | |
| | Höhe ü NN | <2000 m | | |
| | IP | 30 | | |
| | Lagertemperatur | -10 °C to +50 °C | | |
| | Umweltklasse (EN 12101-10) | Klasse I | | |

5.1 Ważne Instrukcje

WANE - BEZPIECZEŃSTWO

Należy dokładnie przeczytać całą niniejszą instrukcję przed dokonywaniem jakichkolwiek interwencji technicznych w urządzeniu.

Obsługą urządzenia mogą zajmować się wyłącznie wykwalifikowani pracownicy.

Należy przeprowadzić instalację produktu i przekazanie go do eksploatacji stosując się opisanej poniżej sekwencji. Kolejność kroków jest ważna i należy jej przestrzegać.

Odciąć zasilanie sieciowe przed dokonaniem jakiegokolwiek interwencji w urządzeniu.

Zasilacz należy wyposażyć w umieszczone przed nim:

- dwubiegunowy odłącznik;
- wyłącznik: 4 A - Krzywa D.

Urządzenie należy przenosić ostrożnie i przechowywać we właściwych warunkach (wilgotności temperatura).

Instalator musi sprawdzić, czy urządzenie nie zostało uszkodzone w trakcie transportu oraz instalacji. Uszkodzony produkt może spowodować poważne obrażenia. Niedozwolone jest podłączenie uszkodzonego produktu do sieci zasilającej.

Niedozwolone jest podłączenie urządzenia do sieci zasilającej, jeżeli nie przymocowano go prawidłowo do ściany a jego obudowy nie podłączono prawidłowo do uziemienia ochronnego (patrz pierwszy krok instalacji). Zastąpienie oryginalnego akumulatora akumulatorem nieprawidłowego rodzaju może prowadzić do zagrożenia wybuchem. Zużyte akumulatory należy utylizować zgodnie z wymaganiami dotyczącymi recyklingu.

Urządzenie jest urządzeniem klasy A. W warunkach domowych może ono spowodować zakłócenia radiowe. W takim przypadku użytkownik musi podjąć odpowiednie środki.

Użyć 4 wkrętów o średnicy do 5 mm. Kołki i wkręty muszą być dostosowane do rodzaju ściany. Poszczególne kołki mocujące/wkręty muszą utrzymywać minimalny ciężar równy 20 kg (80 kg podzielone na poszczególne wkręty mocujące).



Symbol zagrożenia porażeniem prądem elektrycznym



Zacisk uziemienia ochronnego

Typowe zastosowania

SPS (ang. Safety Power Supply) to zasilacz z podtrzymaniem akumulatorowym, z dwoma wyjściami 24 V DC. Jest to wysokowydajny zasilacz przełączający zabezpieczony przed przeciążeniem i zwarciami.

Zalecany jest szczególnie jako pomocniczy zasilacz do elementów systemów wykrywania pożarów takich jak elektromagnesy, urządzenia powiadomieniowe itp

Zgodność z normami



DoP Nos:

SPS-24-1A5/BNS: SPS1A5CE
SPS-24-2A5/BNS: SPS2A5CE
SPS-24-4A5/BNS: SPS4A5CE

Ten produkt spełnia wymagania następujących norm:











- EN54-4: 1997/A1:2003/A2:2006;
- EN12101-10:2005 klasa A Klasa środowiskowa 1

Instrukcja dot. recyklingu

Odpadów elektrycznych nie należy usuwać razem z odpadami domowymi. Należy przekazywać je do recyklingu, jeżeli istnieją odpowiednie udogodnienia. Należy zasięgnąć porady dotyczącej recyklingu u lokalnych organów władzy lub u sprzedawcy detalicznego.



5.2 Praca / opis diod

| | Kolor | Status |
|---|---------------------|---|
| Power ON  | Zielony | Obecna jest sieć zasilająca i/lub akumulatory. |
| General fault  | Żółty | W SPS występuje co najmniej jedna awaria. Zostaje wówczas aktywowany także przekaźnik awarii ogólnej. |
| Mains ~ fault  | Żółty | Brak sieci zasilającej lub jej wartość nie mieści się w zakresie. |
| Charge fault  | Żółty | <ul style="list-style-type: none"> • Brak akumulatorów; lub • Napięcie akumulatorów nie mieści się w zakresie; lub • Nie dochodzi do ładowania; lub • Poziom rezystancji akumulatorów przekroczył próg. |
| Ω level  | Żółty lub Niebieski | |
| Out 1  | | |
| Out 2  | | |
| EN 54-4 : A2 EN 12101-10 EATON SPS Input activated  | Zielony | <p>Poziom rezystancji akumulatorów (zobacz poniższe uwagi):</p> <ul style="list-style-type: none"> •  Niski •  Średni •  Wysoki <ul style="list-style-type: none"> • Obie diody migają: osiągnięto próg domyślny. Aktywowano awarię akumulatora. • Wł.: wyjście 1/2 jest zasilane. • WYŁ.: wyjście 1/2 nie jest zasilane. • Miga: wyjście 1/2 w trybie awarii (np.: zwarcie lub przeciążenie) <p>Wł. gdy wejście jest aktywowane. Potem wyjście 1 zostaje dezaktywowane (wyjście 2 pozostaje aktywowane). Tę dezaktywację można opóźnić o 10 minut w zależności od konfiguracji przełącznika.</p> |

Przekaźnik awarii ogólnej Przekaźnik awarii ogólnej zostaje aktywowany, gdy w SPS występuje co najmniej jedna awaria.

Wejście użytkownika To wejście służy do zdalnego aktywowania lub dezaktywowania wyjścia 1. Wejście zostaje aktywowane wtedy, gdy pomiędzy dwoma pinami zaciskowymi podane jest zwarcie. Potem wyjście 1 zostaje dezaktywowane (wyjście 2 pozostaje aktywowane). Tę dezaktywację można opóźnić o 10 minut w zależności od konfiguracji przełącznika. Patrz 2 - Podłączanie.

Przykład 1: To wejście może służyć do dezaktywowania wyjścia 1 w trakcie alarmu za pomocą przekaźnika na panelu przeciwpożarowym.

Przykład 2: to wejście może służyć do dezaktywowania wyjścia 1 w trakcie awarii sieci zasilającej za pomocą przekaźnika awarii sieci zasilającej na panelu przeciwpożarowym. To spowoduje zachowanie pojemności akumulatorów dla wyjścia 2.

Samoresetujący się bezpiecznik elektroniczny Oba wyjścia zabezpieczono za pomocą wyłącznika elektronicznego. W przypadku przeciążenia lub zwarcia na wyjściu następuje wyłączenie napięcia na tym wyjściu. W takim przypadku migają diody danego wyjścia. Co 30 sekund zasilacz próbuje załączyć napięcie. Jeżeli nie będzie przeciążenia, wówczas napięcie zostanie przywrócone, w przeciwnym razie pozostanie ono wyłączone aż do następnej próby.

Kontrola wewnętrznego rezystora modułu akumulatorowego Zasilacz sprawdza okresowo wewnętrzny rezystor akumulatora i wyświetla wynik na diodach umieszczonych z przodu. Jeżeli żadna dioda nie jest wyłączona, to oznacza niską rezystancję. Dwie diody włączone oznaczają wysoką rezystancję. Dwie migające diody oznaczają, że przekroczony został próg i aktywowana awaria akumulatora. W tym stanie akumulator nie może doprowadzać dużego natężenia w zakresie napięcia. Przewody akumulatora również należy sprawdzać w przypadku wysokiej rezystancji wewnętrznej.

UWAGA: funkcja ta jest aktywna tylko wtedy, gdy przełącznik nr 5 znajduje się w pozycji ON. Jeśli nie jest aktywowana, wewnętrzna kontrola rezystancji odbywa się jednak diody LED pozostają wyłączone.

5.3 Właściwości techniczne



WAŻNE – BEZPIECZEŃSTWO

Oba wyjścia są zabezpieczone elektronicznie.

| | | SPS-24V-1A5/BNS | SPS-24V-2A5/BNS | SPS-24V-4A5/BNS | |
|-------------------------------------|---|---------------------------|---|--------------------------|--|
| Wejście sieciowe | Napięcie (V_{in}) | | 230 V AC (-15 % ;+10 %) | | |
| | Częstotliwość (F_{in}) | | 50 Hz | | |
| | Maks. prąd skuteczny (przy 195 V) (I_{inmax}) | 1.2 A | 1.5 A | 2 A | |
| | Klasa (EN12101-10) | | I | | |
| | Sieć z punktem neutralnym | | TT, IT | | |
| | Wyłącznik | | Bezpiecznik ołowiowy, promieniowy, zwłoczny (2.5 A) | | |
| Wyjście | Napięcie „Wyj 1” Napięcie „Wyj 2” przy $V_{in} > 195 V$ | 27.5 V (+/-0.5 V) | 27.5 V (+/-0.5 V) | 27.5 V (+/-0.5 V) | |
| | Napięcie „Wyj 1” Napięcie „Wyj 2” przy $V_{in} > 0 V$ | Da 20.4 V do 27 V | Da 20.4V do 27 V | Da 20.4 V do 27 V | |
| | Maks. prąd „Wyj 1” Maks. prąd „Wyj 2” | 1.5 A | 2.5 A | 4.5 A | |
| | Maks. prąd „Wyj 1+Wyj 2” $I_{maxa}=I_{maxb}$ | 1.5 A | 2.5 A | 4.5 A | |
| | Min. prąd „Wyj 1” Min. prąd „Wyj 2” | | 0 A | | |
| | Szczałkowe napięcie tętnień „Wyj 1” i „Wyj 2” | | <1 % | | |
| | Przekaznik | Maks. prąd łączeniowy | | 1 A przy 24 V | |
| | | Maks. napięcie łączeniowe | | 120 V cc / 50 V ac (ELV) | |
| Akumulatory/ ładowarka | Maks. prąd ładowarki | | 1.0 A (+/-0.1 A) | | |
| | Napięcie końcowe | | 21 V | | |
| | Napięcie odcięcia | | 21.0 V (+/-0.6 V) | | |
| | Pojemność akumulatora | 4 Ah | 7 Ah | 17 Ah | |
| | Maks. impedancja wewnętrzna R_{int} max | 0.8 Ω | 0.6 Ω | 0.6 Ω | |
| | Zalecane akumulatory | Yuasa NP4-12 | Yuasa NP7-12 | Yuasa NP17-12 | |
| | Wyłącznik 5x20 (F1) | Bezpiecznik 2 A (F) | Bezpiecznik 3.15 A (F) | Bezpiecznik 6.3 A (F) | |
| | Opóźnienie przełączania (EN12101-10) | | 0 s | | |
| | Środowisko | Wymiary (d×w×g) | | 300×220×175 (mm) | |
| Temperatura pracy | | | -5 °C +40 °C | | |
| Wilgotność względna | | | 20 95 % | | |
| Wysokość | | | <2000 m | | |
| IP | | | 30 | | |
| Temperatura przechowywania | | | -10 °C 50 °C | | |
| Klasa środowiskowa (EN 12101-10) | | | Klasa I | | |

6.1 Instruções Importantes - Português

IMPORTANTE - SEGURANÇA

Leia este manual atenta e integralmente antes de qualquer intervenção técnica no equipamento. Qualquer intervenção apenas deve ser realizada por pessoal qualificado.

A instalação e comissionamento do equipamento deve ser feita na sequência descrita em baixo. A ordem dos passos é importante e deve ser respeitada.

Desligue a alimentação antes de qualquer intervenção no equipamento.

A fonte de alimentação deve ser fornecida a montante com:

- um dispositivo de corte bipolar;
- um disjuntor: 4 A – Curva D.

O equipamento deve ser transportado cuidadosamente e armazenado em condições apropriadas (humidade e temperatura).

O instalador deve verificar que o equipamento não foi danificado durante o transporte e instalação. Um equipamento danificado pode causar lesões graves. Um equipamento danificado nunca deverá ser ligado à tensão de alimentação.

O equipamento nunca deve ser ligado à alimentação se não estiver apropriadamente fixo à parede com o seu invólucro ligado à terra (ver primeiro passo da instalação).

Substituir a bateria original por uma bateria de tipo incorrecto pode resultar em risco de explosão. Baterias usadas devem ser eliminadas de acordo com os regulamentos sobre reciclagem em vigor.

Este é um equipamento de classe A. Num ambiente residencial, este equipamento pode causar interferências em sinais de rádio. Neste caso, o utilizador pode tomar medidas adequadas.

Utilize 4 parafusos com um diâmetro até 5 mm. Buchas e parafusos devem ser adaptados ao tipo de parede. Cada fixação bucha/parafuso deve suportar um peso mínimo de 20Kg (80Kg divididos em cada um dos parafusos) .



Simbolo de risco de choque eléctrico



Terminal terra

Aplicações típicas

A SPS é uma fonte de alimentação suportada por baterias com duas saídas-24V. É uma fonte de alimentação comutável de alta eficiência; protegida contra sobre-alimentações e curto-circuitos.

É especialmente recomendada como fonte auxiliar para componentes de sistemas de detecção de incêndio, tais como electroimans, dispositivos de notificação, etc.

Conformidade com normas



15

DoP Nos:

SPS-24-1A5/BNS: SPS1A5CE

SPS-24-2A5/BNS: SPS2A5CE

SPS-24-4A5/BNS: SPS4A5CE

Este equipamento cumpre com as seguintes normas:











- EN54-4: 1997/A1:2003/A2:2006;
- EN12101-10:2005 classe ambientale A

Instruções reciclagem

Resíduos de produtos eléctricos não devem ser eliminados juntamente com lixo doméstico. Por favor recicle onde existam meios. Verifique com as autoridades locais ou distribuidor as exigências regulamentares.



6.2 Funcionamento, Descrição dos LEDs

| | Cor | Estado |
|---|-----------------|--|
| Power ON  | Verde | Alimentação e/ou baterias estão presentes. |
| General fault  | Amarelo | Existe pelo menos uma falha na SPS. Então o relé de falha geral também é activado. |
| Mains ~ fault  | Amarelo | Sem alimentação ou valores fora dos limites. |
| Charge fault  | Amarelo | <ul style="list-style-type: none"> Sem baterias; ou Tensão das baterias fora dos limites; ou Existe uma falha de carregador; ou Nível de resistência das baterias excedeu o limite. |
| Ω level  | Amarelo ou Azul | Nível de Resistências baterias (ver nota em baixo): <ul style="list-style-type: none">  Baixo  Medio  Alto |
| Out 1  | | |
| Out 2  | Verde | <ul style="list-style-type: none"> Ambos os LEDs piscam: nível limite antigido. É activada uma falha de bateria. ON: output 1/2 está alimentada OFF: output 1/2 não está alimentada. Piscar: output 1/2 em modo falha (ex.: curto-circuito, sobrecarga) |
| EN 54-4 : A2 EN 12101-10 | | |
| EATON SPS | | |
| Input activated  | Verde | ON quando a entrada está activa. Então a output 1 é desactivada (output 2 mantém-se activa). A desactivação pode ser atrasada até 10 minutos dependendo da configuração dos switches. |

| | |
|--|--|
| Relé falha geral | Este relé activa quando existe pelo menos uma falha na SPS. |
| Entrada utilizador | <p>Entrada utilizada para activar ou desactivar remotamente a output 1. A entrada é activada aplicando um curto-circuito aos seus terminais.</p> <p>Então a output 1 é desactivada (output 2 mantém-se activa). Esta desactivação pode ser atrasada até 10 minutos dependendo da configuração dos switches.</p> <p>Ver 2 - Ligação</p> <p>Exemplo 1: Esta entrada pode ser utilizada para desactivar a output 1 durante um alarme utilizando o relé de fogo da central.</p> <p>Exemplo 2: Esta entrada pode ser utilizada para desactivar a output 1 durante uma falha de alimentação utilizando o relé de falha de alimentação da central. Irá manter capacidade de baterias para a output 2.</p> |
| Fusível electrónico rearmável | Ambas as Output são protegidas por um fusível electrónico. Em caso de sobrecarga ou curto-circuito numa saída, a tensão desta é desligada. Neste caso o led da saída pisca. A cada 30 segundos a central tentará repor a tensão. Se a sobrecarga não estiver presente a tensão é repostada, caso contrário a output mantém-se desligada até à próxima tentativa. |
| Controlo da resistência interna do pack de baterias | <p>A fonte de alimentação verifica periodicamente a resistência interna da bateria e mostra o resultado nos LEDs frontais. Sem LEDs acesos significa baixa resistência. Dois LEDs acesos significa resistência alta. Se dois LEDs piscam, então o limite foi excedido e é gerada uma falha de bateria. Nesta condição a bateria perde a capacidade de fornecer corrente elevada na gama de tensão. Os cabos da bateria também devem ser verificados em caso de alta resistência interna.</p> <p>NOTA: esta função activa apenas quando o switch nº5 está na posição ON. Caso contrário, o teste de resistência interna é efetuado, mas os LEDs mantêm-se apagados.</p> |

6.3 Características Técnicas

⚠ IMPORTANTE

Ambas as outputs são protegidas eletronicamente.

| | SPS-24V-1A5/BNS | SPS-24V-2A5/BNS | SPS-24V-4A5/BNS | |
|--|--|--------------------------|--------------------------|-------------------|
| Entrada rede | Tensão (V_{in}) | 230 V ac (-15 % ; +10 %) | | |
| | Frequência (F_{in}) | 50 Hz | | |
| | Corren. max.RMS (@195 V)(I_{inmax}) | 1,2 A | 1,5 A | 2 A |
| | Classe (EN12101-10) | I | | |
| | Sistema de neutro | TT, IT | | |
| | Fusível | Fusível Radial (2,5 A) | | |
| Output | Tensão "Out 1" Tensão "Out 2" a $V_{in} > 195 V$ | 27,5 V (+/-0,5 V) | 27,5 V (+/-0,5 V) | 27,5 V (+/-0,5 V) |
| | Tensão "Out 1" Tensão "Out 2" a $V_{in} > 0 V$ | 20,4 V a 27 V | 20,4 V a 27 V | 20,4 V a 27 V |
| | Corren. Máx. "Out 1" Corren. Máx. "Out 2" | 1,5 A | 2,5 A | 4,5 A |
| | Corren. Máx "Out 1+Out 2" $I_{maxa}=I_{maxb}$ | 1,5 A | 2,5 A | 4,5 A |
| | Corren. Min. "Out 1" Corren. Min. "Out 2" | | 0 A | |
| | Tensão residual ripple "Out 1" & "Out 2" | | <1 % | |
| | Relè | Corrente máxima | 1 A @ 24 V | |
| | | Tensão máxima | 120 V cc / 50 V ac (ELV) | |
| | Baterias/carregador | Corren. Máx. Carregador | 1,0 A (+/-0,1 A) | |
| | | Tensão final | 21 V | |
| Tensão de corte | | 21,0 V (+/-0,6 V) | | |
| Capacidade bateria | | 4 Ah | 7 Ah | 17 Ah |
| Resistência interna max $R_{int max}$ | | 0,8 Ω | 0,6 Ω | 0,6 Ω |
| Baterias recomendadas | | Yuasa NP4-12 | Yuasa NP7-12 | Yuasa NP17-12 |
| Fusível 5x20 (F1) | | Fusível 2 A (F) | Fusível 3,15 A (F) | Fusível 6,3 A (F) |
| Atraso comutação (EN12101-10) | | 0 s | | |
| Ambiente | Dimensões (LxAXP) | 300x220x175 (mm) | | |
| | Temperatura funcionamento | -5 °C to +40 °C | | |
| | Humidade relativa | 20 to 95 % | | |
| | Altitude | <2000 m | | |
| | IP | 30 | | |
| | Temperatura armazenamento | -10 °C a +50 °C | | |
| | Classe ambiental (EN 12101-10) | Classe I | | |

7.1 Belangrijke Instructies - Nederlands

BELANGRIJK - VEILIGHEID

Lees deze handleiding zorgvuldig en in zijn geheel voordat u met dit apparaat aan de slag gaat.

De beschreven werkzaamheden mogen alleen door daartoe gekwalificeerd personeel worden uitgevoerd.

Installatie en instellingen van deze power supply moeten in de hieronder beschreven volgorde worden uitgevoerd. De volgorde van de stappen is belangrijk en moet daarom in acht worden genomen.

Sluit de voedingsspanning af voordat u met dit apparaat aan de slag gaat.

De stroomtoevoer van de power supply moet voorzien zijn van:

- een 2-polige aan/uit schakelaar
- een zekering: 4 A - D karakteristiek.

De power supply moet voorzichtig worden vervoerd en onder goede condities (vochtigheid en temperatuur) worden opgeslagen c.q. geïnstalleerd.

Zorg er voor dat de power supply tijdens vervoer en installatie niet beschadigd raakt.

Een beschadigde power supply kan tot ernstige verwondingen leiden. Sluit nooit een beschadigde power supply aan op de netspanning.

De power supply mag nooit op de netvoeding worden aangesloten als hij niet op de juiste wijze aan de muur is bevestigd. De behuizing moet aangesloten zijn op een beschermingsleiding (aarde). Zie de eerste stap van de installatie.

Het vervangen van de originele accu door een accu van een onjuist type kan leiden tot explosiegevaar. Gebruikte accu's dienen overeenkomstig de daarvoor geldende voorschriften te worden afgevoerd.

Deze Safety Power Supply (SPS) is een klasse A apparaat. In een woonomgeving kan de power supply storing in de etherfrequenties veroorzaken. In dat geval dient de gebruiker de nodige maatregelen te treffen.

Gebruik 4 stuks M5 schroeven. Pluggen en schroeven dienen te worden afgestemd op de soort muur. Elke bevestigingsschroef moet op z'n minst een gewicht van 20kg kunnen dragen (= 80kg verdeeld over 4 schroeven).



Kans op elektrische schok



Aarde-aansluiting

Typische toepassingen

De SPS is een power supply voor twee 24VDC uitgangen met twee noodstroomaccu's. Het is een zeer efficiënte geschakelde voedingseenheid beveiligd tegen overbelasting en kortsluiting.

Het wordt speciaal aanbevolen als een aanvullende voedingseenheid voor onderdelen van een branddetectiesysteem zoals elektromagneten, informatiepanelen enz.

Verklaring van conformiteit



DoP Nos:

SPS-24-1A5/BNS: SPS1A5CE
SPS-24-2A5/BNS: SPS2A5CE
SPS-24-4A5/BNS: SPS4A5CE

Dit apparaat voldoet aan de volgende normeringen:











- EN54-4: 1997/A1:2003/A2:2006;
- EN12101-10:2005 klasse A Mil. klasse 1.

Afvalverwerking

Elektrische afvalproducten behoren niet tot het huishoudelijk afval. Waar mogelijk dient dit gescheiden te worden aangeleverd. Raadpleeg hiervoor het lokale afvalverwerkingsbedrijf.



7.2 Bediening / LED-functies

| | Kleur | Status |
|---|---------------|---|
| Power ON  | Groen | Netvoeding en/of accu's aanwezig. |
| General fault  | Geel | Er is minstens 1 storing in de power supply. Het relais voor algemene storing is geactiveerd. |
| Mains ~ fault  | Geel | Netvoeding niet aanwezig of onvoldoende |
| Charge fault  | Geel | <ul style="list-style-type: none"> • Accu's niet aanwezig, of • Accuspanning onvoldoende, of • Storing in acculader, of • Het niveau van de accuweerstand is overschreden. |
| Ω level  | Geel of blauw | Accuweerstand (zie opmerking beneden): <ul style="list-style-type: none"> •  Laag •  Normaal •  Hoog |
| Out 1  | | |
| Out 2  | Groen | <ul style="list-style-type: none"> • Beide LED's knipperen indien de standaardwaarde voor een storingsmelding is overschreden. Een melding van een accustoring is geactiveerd. • AAN: Uitgang 1/2 ontvangt voedingspanning • UIT: Uitgang 1/2 ontvangt geen voedingspanning • Knippert: Uitgang 1/2 in storingmodus. (bijv. sluiting of overbelasting). |
| EN 54-4 : A2 EN 12101-10 | | |
| EATON SPS | | |
| Input activated  | Groen | AAN: Ingang actief. Uitgang 1 is uitgeschakeld (uitgang 2 blijft actief). Afhankelijk van de instelling van de schakelaars kan deze uitschakeling tot tien minuten worden vertraagd. |

Relais voor algemene storing

Dit relais is actief indien de power supply tenminste 1 storing heeft..

Gebruikersingang

Deze ingang wordt gebruikt voor het in- en uitschakelen van uitgang 1. De ingang is ingeschakeld na een sluiting over de twee uitgangspennen.

Uitgang 1 is uitgeschakeld (uitgang 2 blijft actief). Afhankelijk van de instelling van de schakelaars kan deze uitschakeling tot tien minuten worden vertraagd.

Zie 2 - Aansluitingen.

Voorbeeld 1: Deze ingang kunt u gebruiken voor het uitschakelen van uitgang 1 gedurende een alarmmelding die het relais van het brandpaneel gebruikt.

Voorbeeld 2: Deze ingang kunt u gebruiken voor het uitschakelen van uitgang 1 gedurende een storing in de netspanning, waarbij het betreffende relais van het brandpaneel wordt gebruikt. Het accuvermogen voor uitgang 2 blijft hierbij ongewijzigd.

Zelfherstellende elektronische zekering

Beide uitgangen worden elektronisch beveiligd door een zelfherstellende zekering. In geval van overbelasting of sluiting wordt de betreffende uitgang uitgeschakeld en knippert de LED van deze uitgang. Na 30 seconden probeert de power supply de uitgang weer in te schakelen. Als de storing is opgeheven zal de uitgang weer de gewenste spanning leveren. Is dit niet het geval, dan blijft de uitgang 30 seconden uitgeschakeld tot de volgende poging.

Controle op interne weerstand van het accu-pakket

De power supply controleert regelmatig de interne weerstand van de accu's en toont het resultaat via de LED's op het front. Geen brandende LED's betekent een lage weerstand. Twee brandende LED's betekent een hoge weerstand. Als de twee LED's knipperen is de standaardwaarde voor een storingsmelding overschreden en wordt een melding van een accustoring geactiveerd. In deze situatie zijn de accu's niet in staat om het gewenste vermogen te leveren. Bij een hoge weerstand dient tevens de bekabeling van de accu's te worden gecontroleerd.

Opmerking: Deze functionaliteit is alleen geactiveerd wanneer schakelaar nummer 5 in de "ON" positie staat. Wanneer deze niet actief is zal de interne weerstandstest worden uitgevoerd, echter de LED's blijven uit.

7.3 Technische gegevens

 **BELANGRIJK**

Beide uitgangen zijn elektronisch beveiligd door middel van een zelfherstellende zekering.

| | SPS-24V-1A5/BNS | SPS-24V-2A5/BNS | SPS-24V-4A5/BNS | |
|--|---|------------------------------|--------------------------|------------------|
| Netwerk ingang | Voltage (V_{in}) | 230 V ac (-15 % ; +10 %) | | |
| | Frequentie (F_{in}) | 50 Hz | | |
| | Max. stroomverbr. RMS (@195 V)(I_{inmax}) | 1.2 A | 1.5 A | 2 A |
| | Klasse (EN12101-10) | I | | |
| | Neutraal systeem | TT, IT | | |
| | Zekering | 2,5 A traag, radiaal bedraad | | |
| Uitgang | Voltage "UIT1" Voltage "UIT2" a $V_{in} > 195$ V | 275 V (+/-0.5 V) | 275 V (+/-0.5 V) | 275 V (+/-0.5 V) |
| | Voltage "UIT1" Voltage "UIT2" a $V_{in} > 0$ V | 20.4 V a 27 V | 20.4 V a 27 V | 20.4 V a 27 V |
| | Max. stroomverbr. "UIT1" Max. stroomverbr. "UIT2" | 1.5 A | 2.5 A | 4.5 A |
| | Max. stroomverbr. "UIT1" Max. stroomverbr. "UIT2" $I_{max,a} = I_{max,b}$ | 1.5 A | 2.5 A | 4.5 A |
| | Min. stroomverbr. "UIT1" Min. stroomverbr. "UIT2" | | 0 A | |
| | Spanningsrimpel "UIT1" en "UIT2" | | <1 % | |
| | Relais | Max. geschakeld verbruik | 1 A @ 24 V | |
| | | Max. geschakelde spann. | 120 V cc / 50 V ac (ELV) | |
| | Accu's/acculader | Max. vermogen | 1.0 A (+/-0.1 A) | |
| | | Eindspanning | 21 V | |
| Afsluitspanning | | 21.0 V (+/-0.6 V) | | |
| Accuvermogen | | 4 Ah | 7 Ah | 17 Ah |
| Max. interne impedantie $R_{int,max}$ | | 0.8 Ω | 0.6 Ω | 0.6 Ω |
| Aanbevolen accu's | | Yuasa NP4-12 | Yuasa NP7-12 | Yuasa NP17-12 |
| Zekering 5x20 (F1) | | Zek. 2 A (F) | Zek. 3.15 A (F) | Zek. 6.3 A (F) |
| Schakelvertraging (EN12101-10) | | 0 s | | |
| Behuizing en omgeving | Afmetingen (LxHxD) | 300x220x175 (mm) | | |
| | Omgevingstemperatuur | -5 °C to +40 °C | | |
| | Rel. vochtigheidsgraad | 20 to 95 % | | |
| | Hoogte | <2000 m | | |
| | IP-klasse | 30 | | |
| | Opslagtemperatuur | -10 °C a +50 °C | | |
| | Milieuklasse (EN 12101-10) | Klasse 1 | | |

Sub-Contents

| | | |
|----------|---|-----------|
| 8 | INSTALLATION AND MAINTENANCE..... | 24 |
| 8 | INSTALLATION ET MAINTENANCE..... | 24 |
| 8 | INSTALLAZIONE E MANUTENZIONE..... | 24 |
| 8 | INSTALLATION UND WARTUNG..... | 24 |
| 8 | INSTALACJA I KONSERWACJA..... | 24 |
| 8 | INSTALAÇÃO E MANUTENÇÃO..... | 24 |
| 8 | INSTALLATIE EN ONDERHOUD..... | 24 |
| | 8.1 Fixing..... | 25 |
| | 8.1 Fixation..... | 25 |
| | 8.1 Fissaggio..... | 25 |
| | 8.1 Befestigung..... | 25 |
| | 8.1 Mocowanie..... | 25 |
| | 8.1 Fixação..... | 25 |
| | 8.1 Montage..... | 25 |
| | 8.2 Connecting..... | 27 |
| | 8.2 Raccordement..... | 27 |
| | 8.2 Collegamento..... | 27 |
| | 8.2 Anschluß..... | 27 |
| | 8.2 Podłączenie..... | 27 |
| | 8.2 Ligação..... | 27 |
| | 8.2 Aansluitingen..... | 27 |
| | 8.3 Closing and Powering Up..... | 30 |
| | 8.3 Refermer et mettre sous tension..... | 30 |
| | 8.3 Chiusura e alimentazione..... | 30 |
| | 8.3 Schließen und Einschalten..... | 30 |
| | 8.3 Zamykanie i załączanie zasilanie..... | 30 |
| | 8.3 Fecho e alimentação..... | 30 |
| | 8.3 Afsluiten en opstarten..... | 30 |
| | 8.4 Replacing Fuse..... | 31 |
| | 8.4 Remplacer un fusible..... | 31 |
| | 8.4 Sostituzione del fusibile..... | 31 |
| | 8.4 Sicherungswechsel..... | 31 |
| | 8.4 Wymiana bezpiecznika..... | 31 |
| | 8.4 Substituir fusivel..... | 31 |
| | 8.4 Zekering vervangen..... | 31 |
| | 8.5 Replacing Battery..... | 32 |
| | 8.5 Remplacer les batteries..... | 32 |
| | 8.5 Sostituzione delle batterie..... | 32 |
| | 8.5 Batteriewechsel..... | 32 |
| | 8.5 Wymiana akumulatorów..... | 32 |
| | 8.5 Substituir baterias..... | 32 |
| | 8.5 Accu's vervangen..... | 32 |

Installation

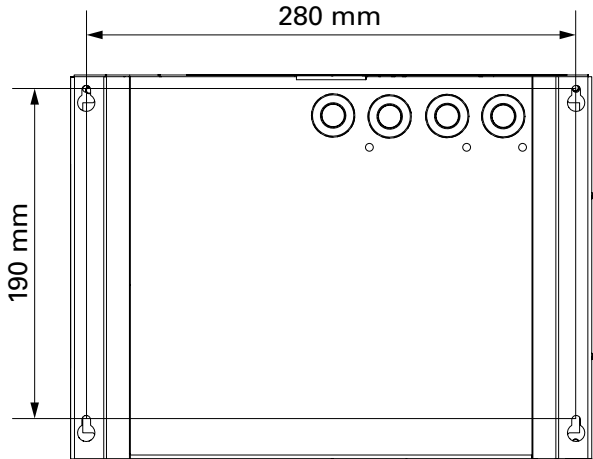
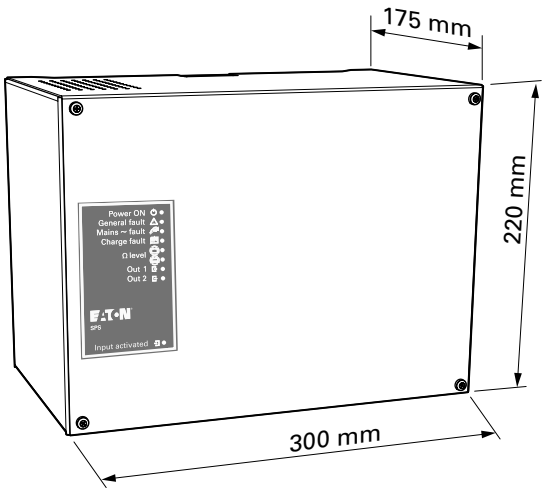
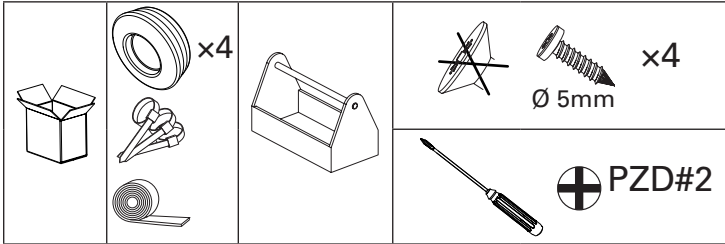
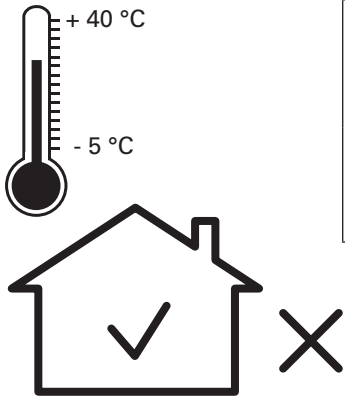

8.1 Fixing

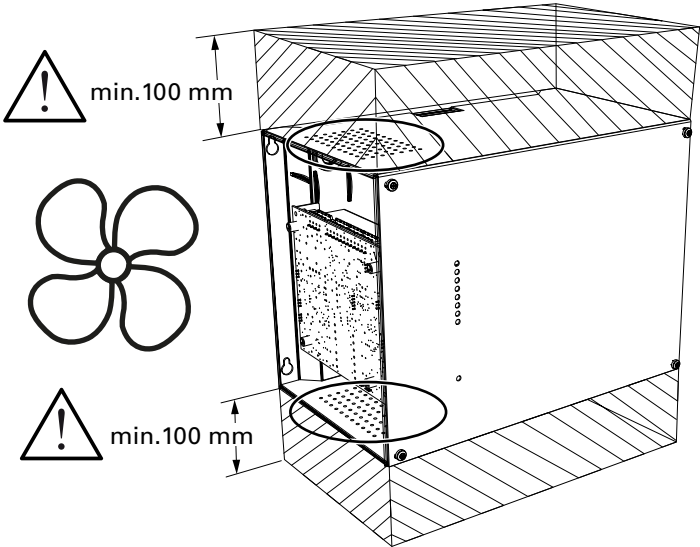
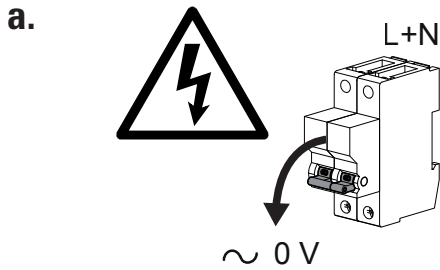

Installation & Maintenance

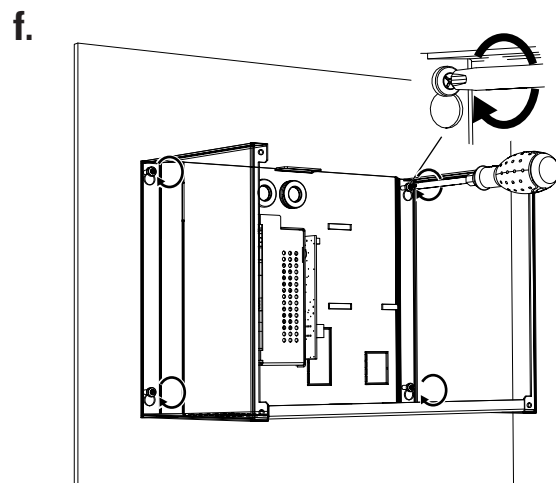
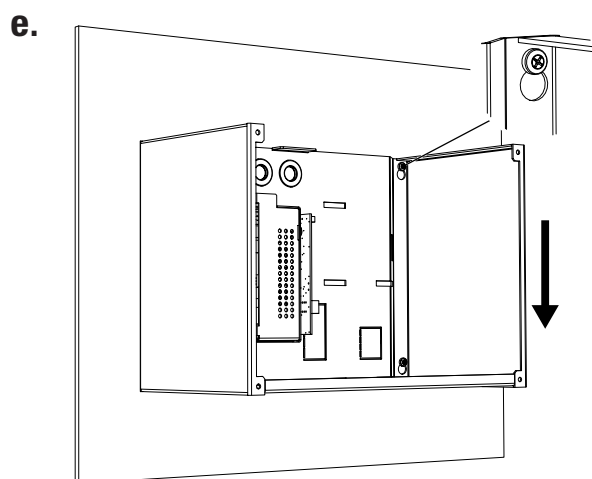
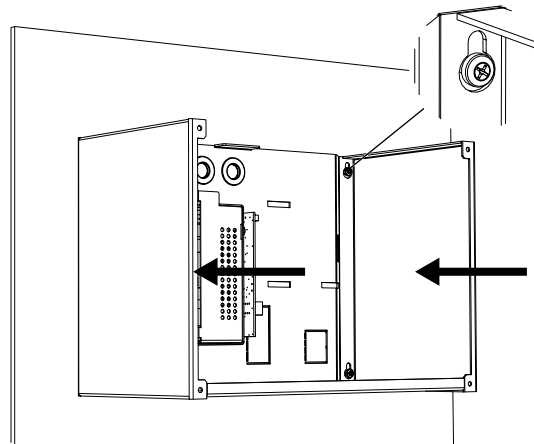
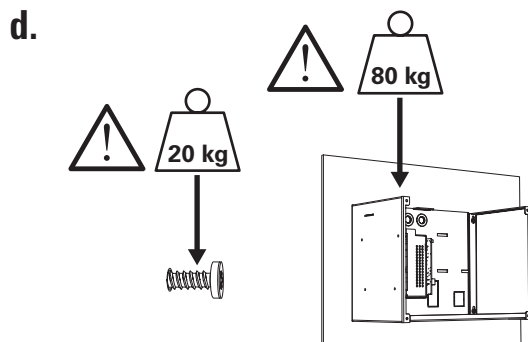
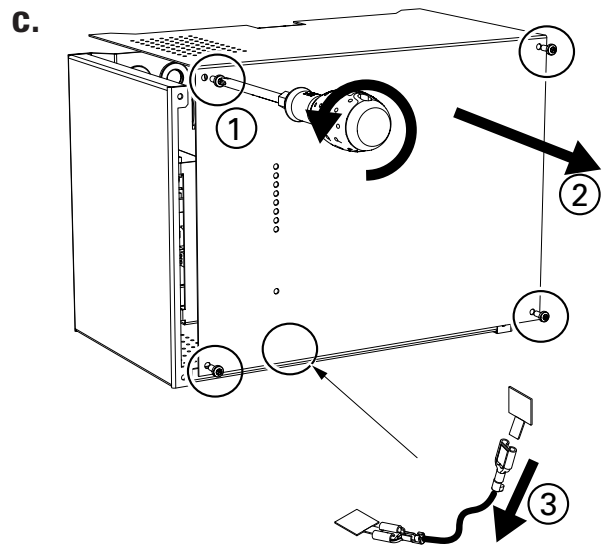
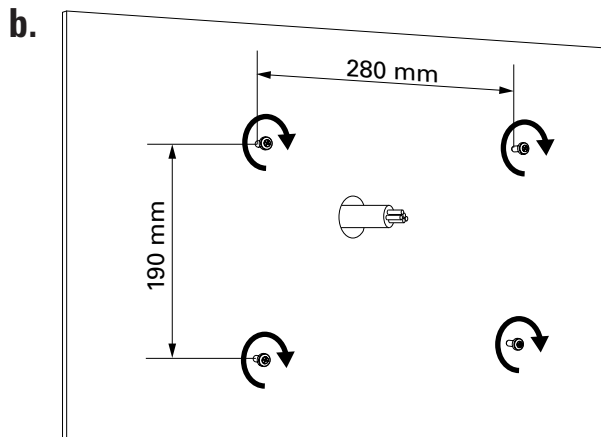

8.2 Connecting

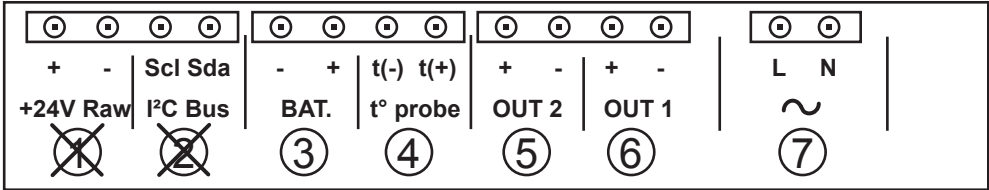

Power/Earth

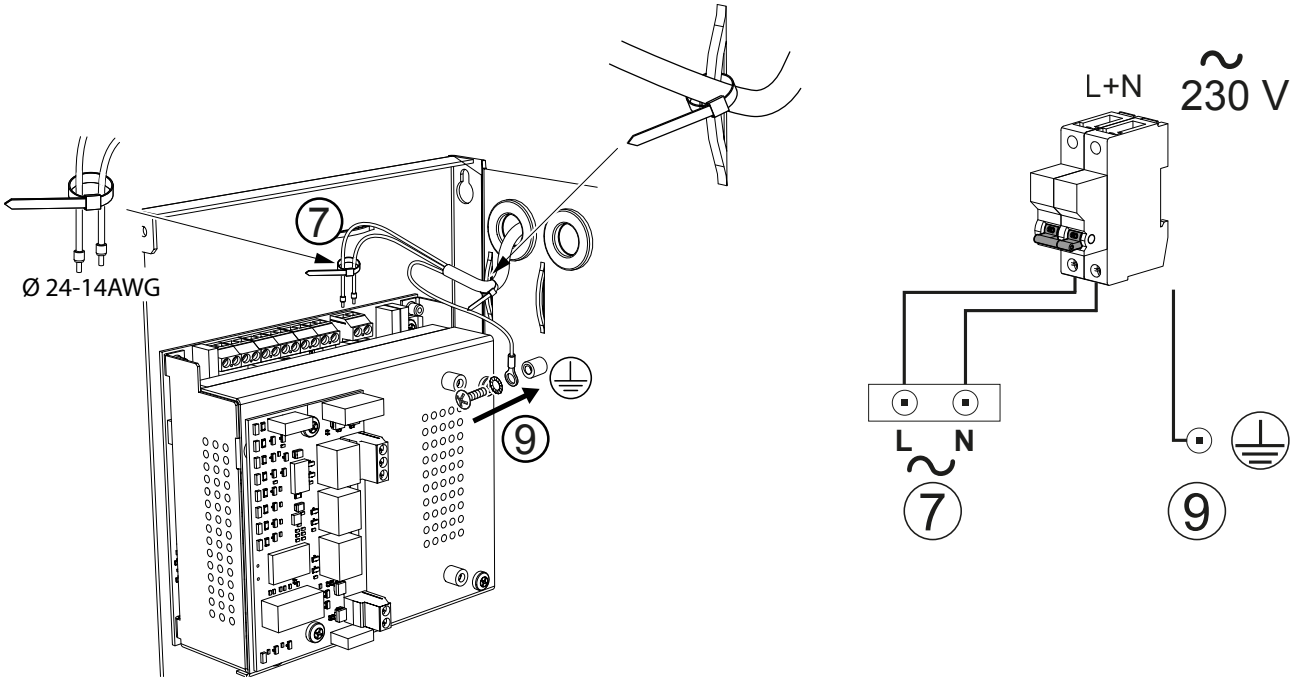

OUT 1/2

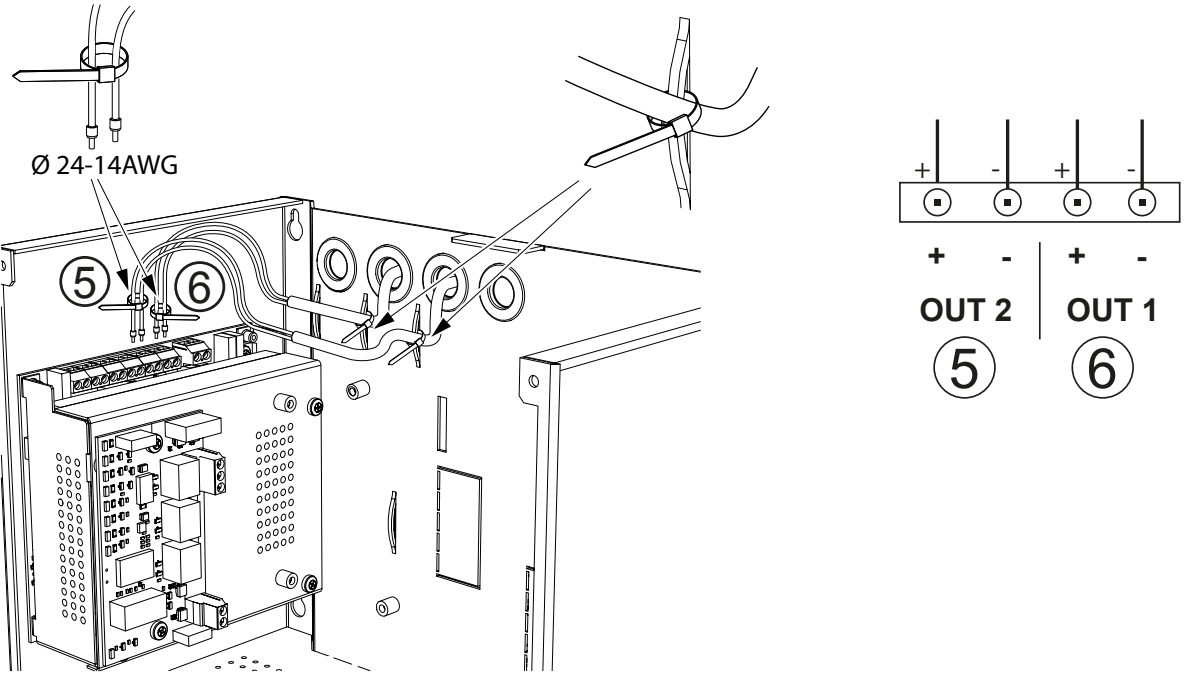

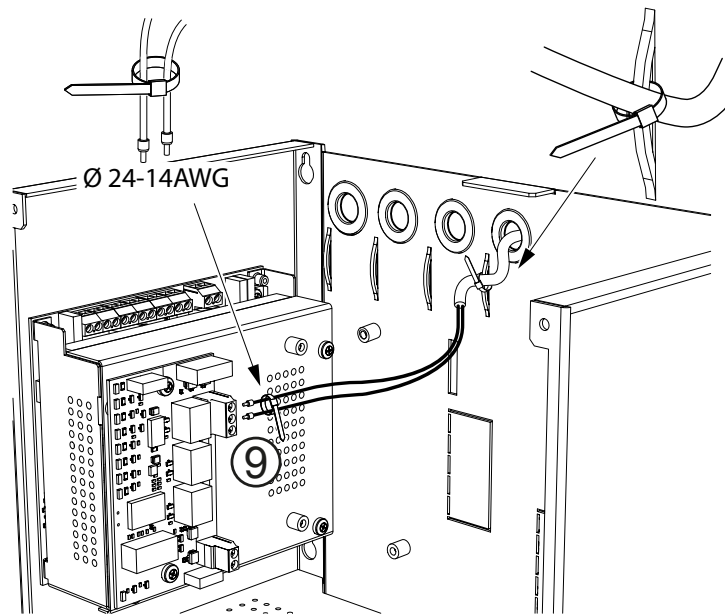
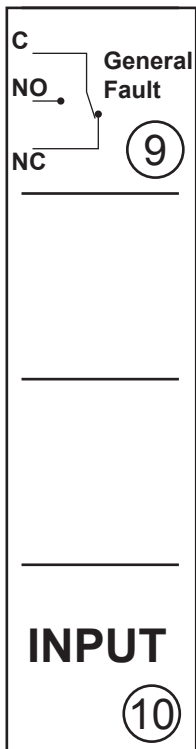

9 General Fault

Normal State (No fault)

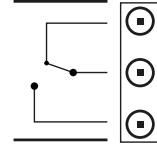

Fault State

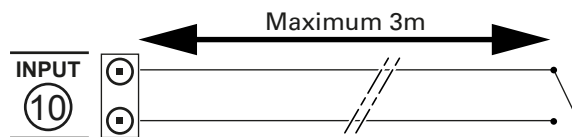
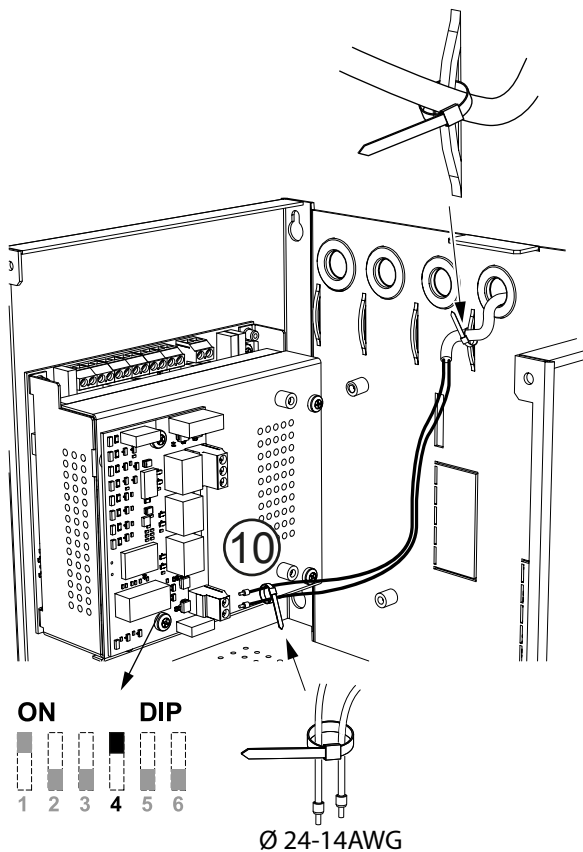
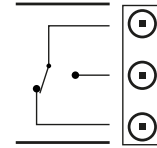

| Switch | ON | DIP | ON | DIP |
|----------|--------------------|--------------------|-------------|-------------|
| INPUT 10 | | | | |
| | OUT 1 = 24V | OUT 1 = 24V | OUT 1 = 24V | OUT 1 = 24V |
| | OUT 1 24V → 0V | OUT 1 24V → 0V | | |

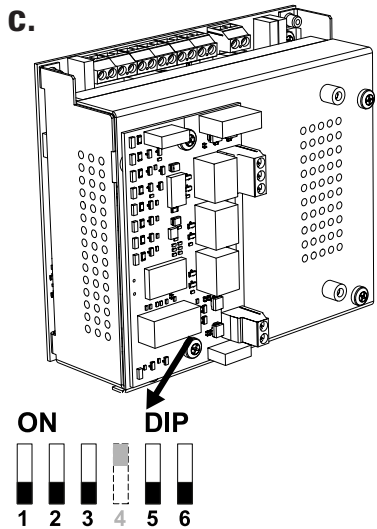
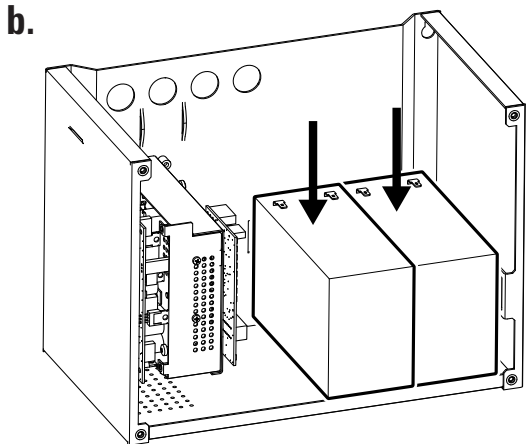
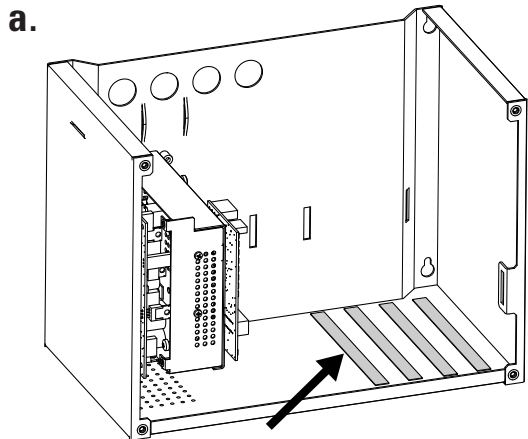

 12 V - 4 Ah --> SPS-24-1A5/BNS

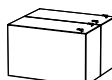
 12 V - 7 Ah --> SPS-24-2A5/BNS

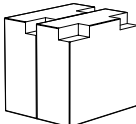
 12 V - 17 Ah --> SPS-24-4A5/BNS

t° probe

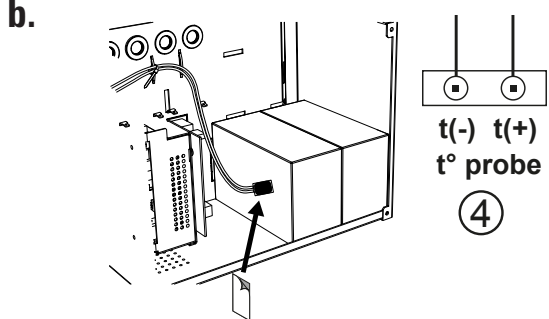
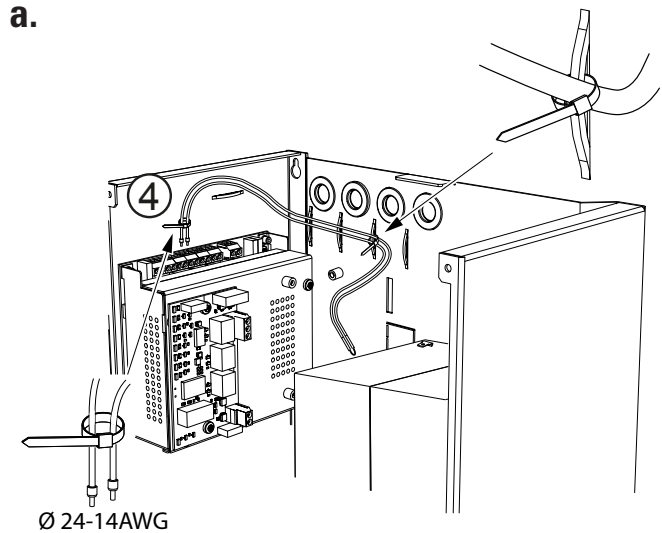

BAT.

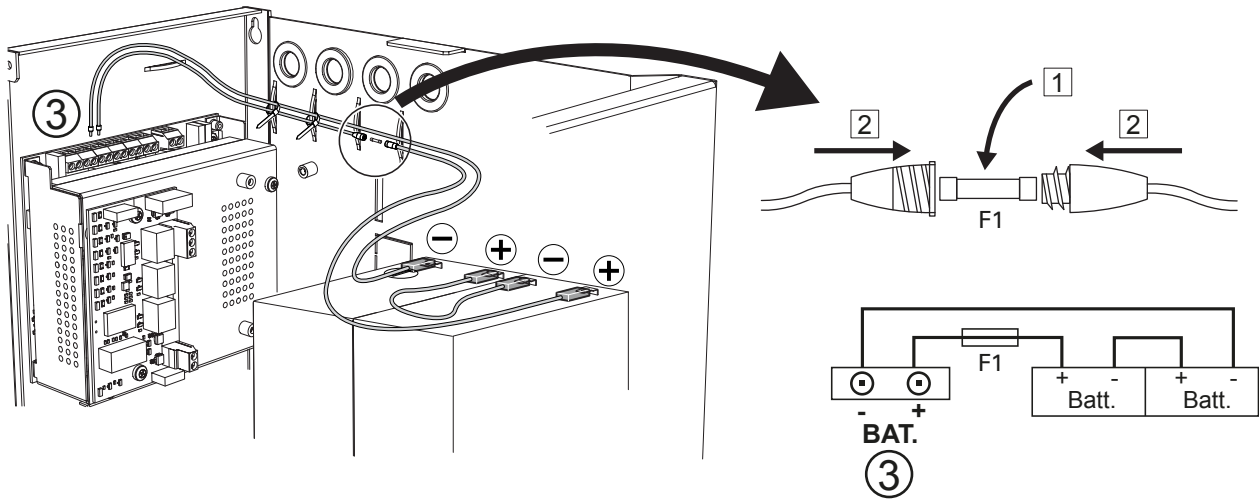

8.3 Closing and Powering Up

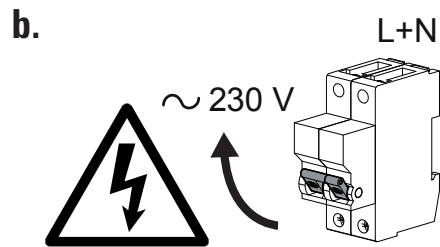
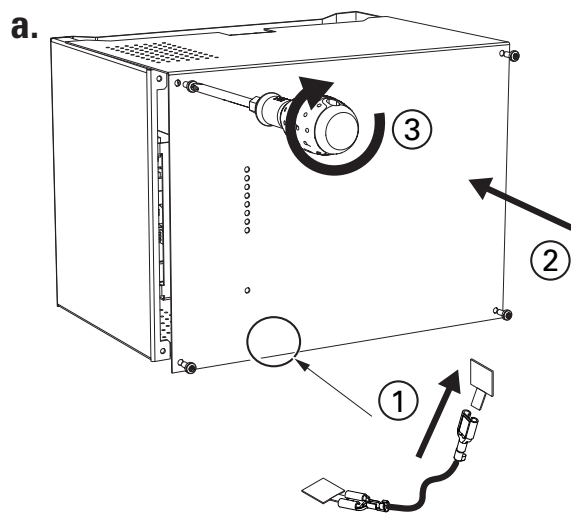

Maintenance

8.4 Replacing Fuse

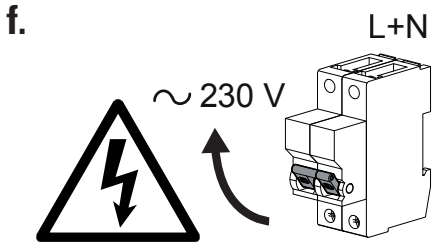
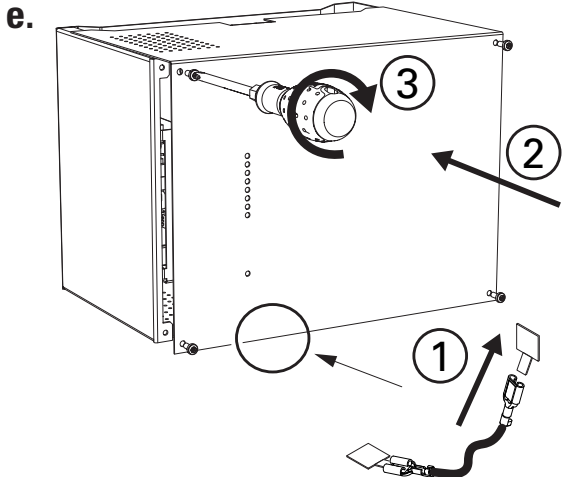
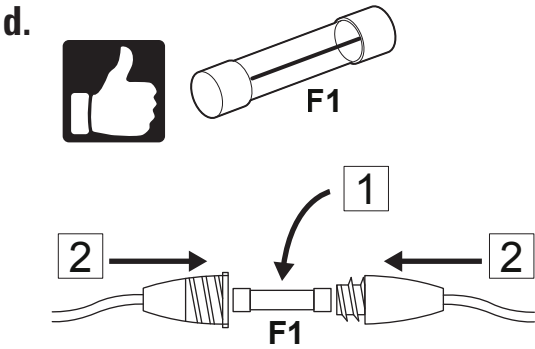
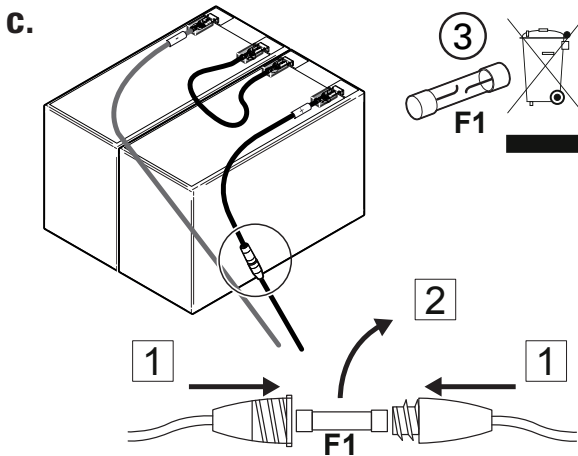
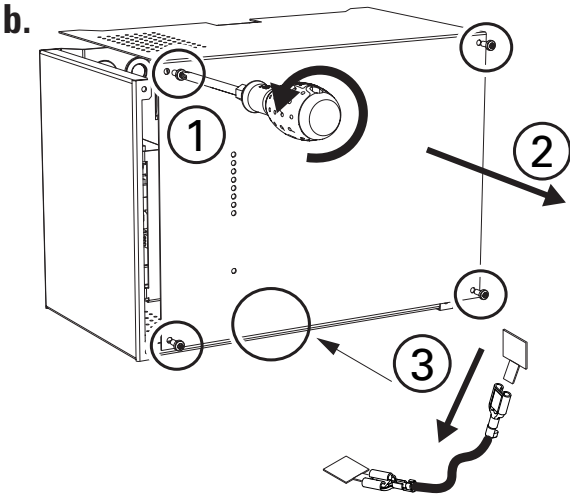
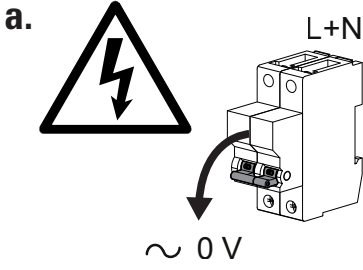

8.5 Replacing Batteries

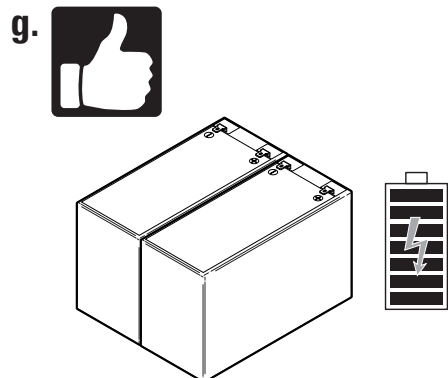
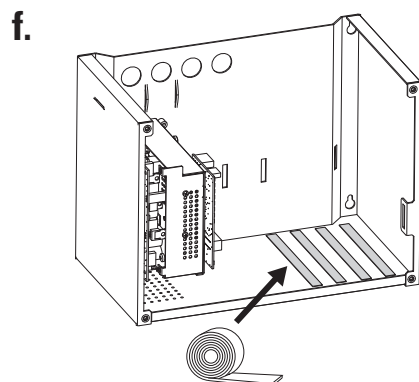
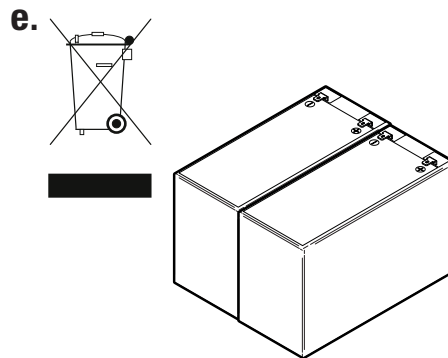
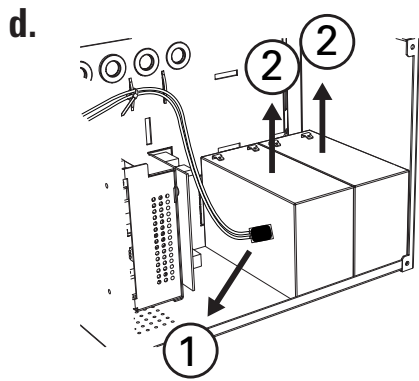
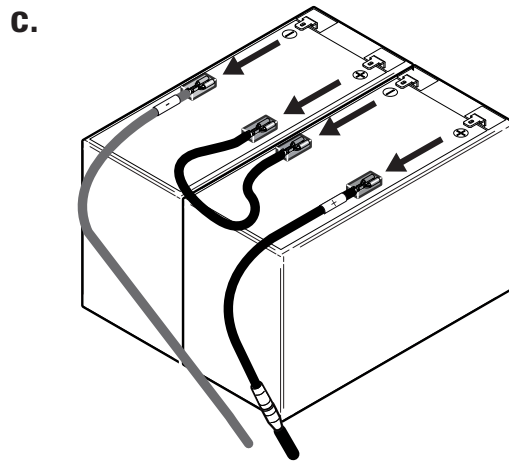
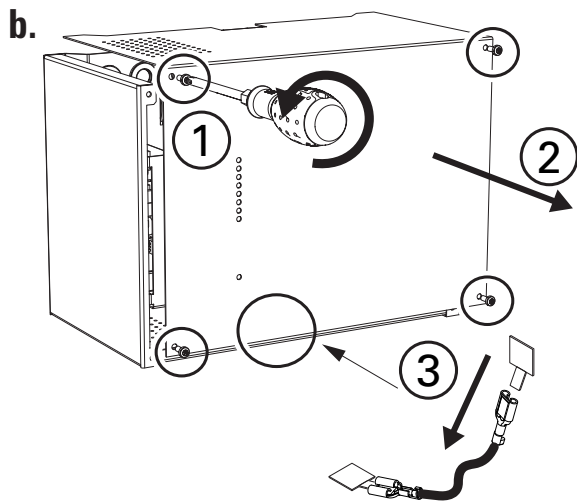
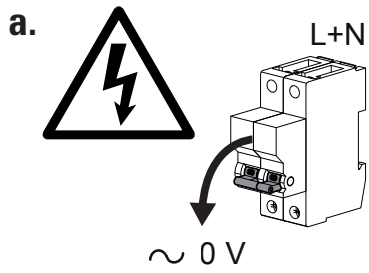

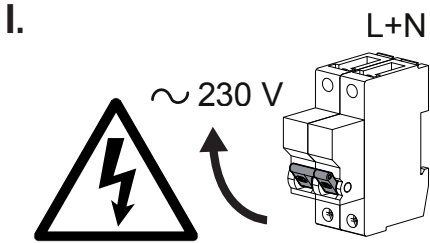
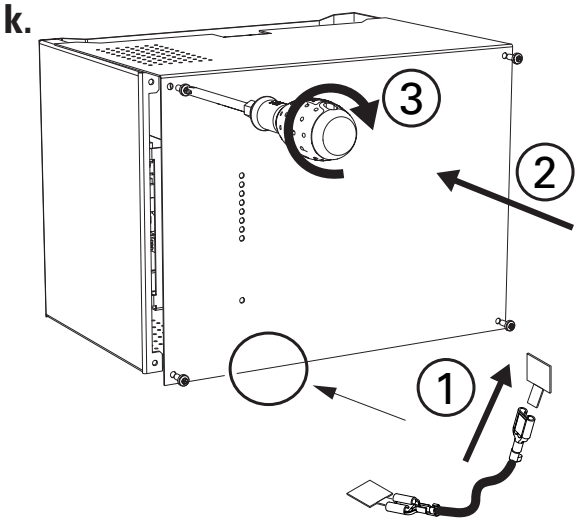
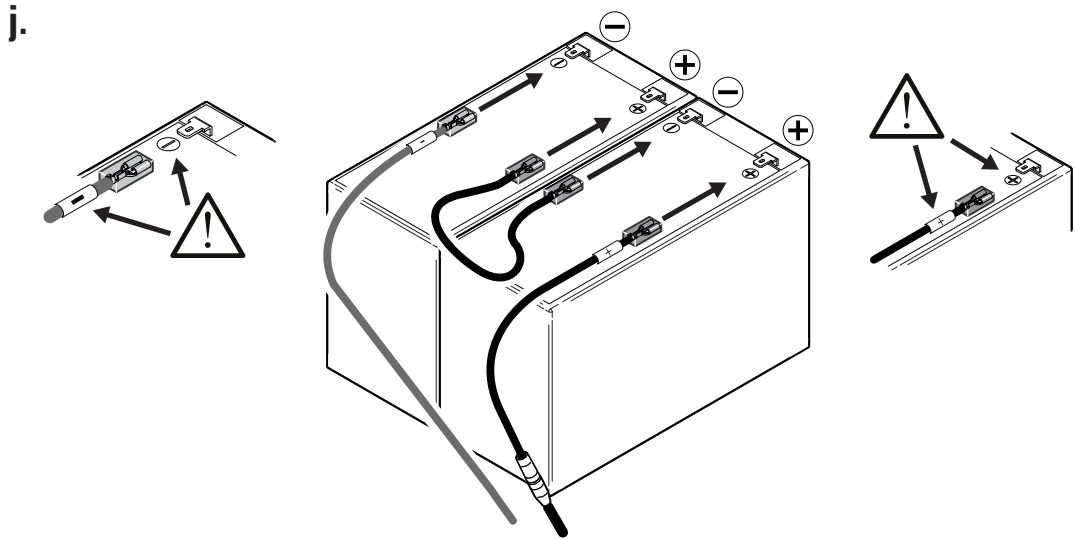
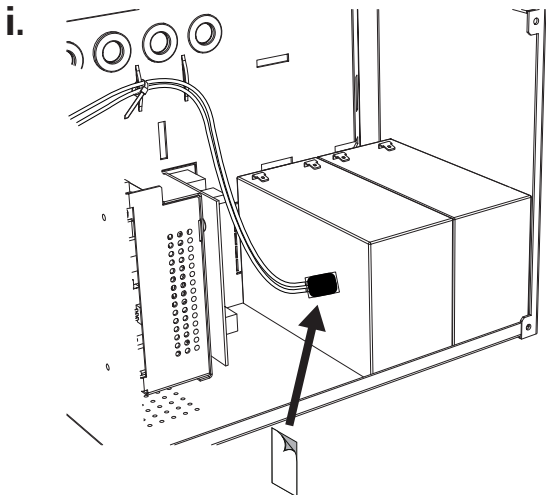
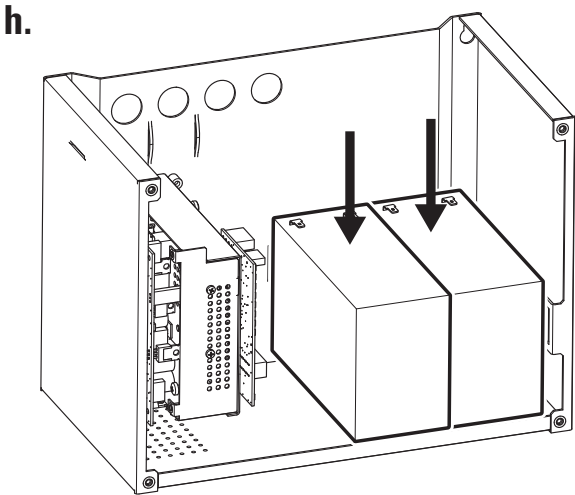

9. Autonomy

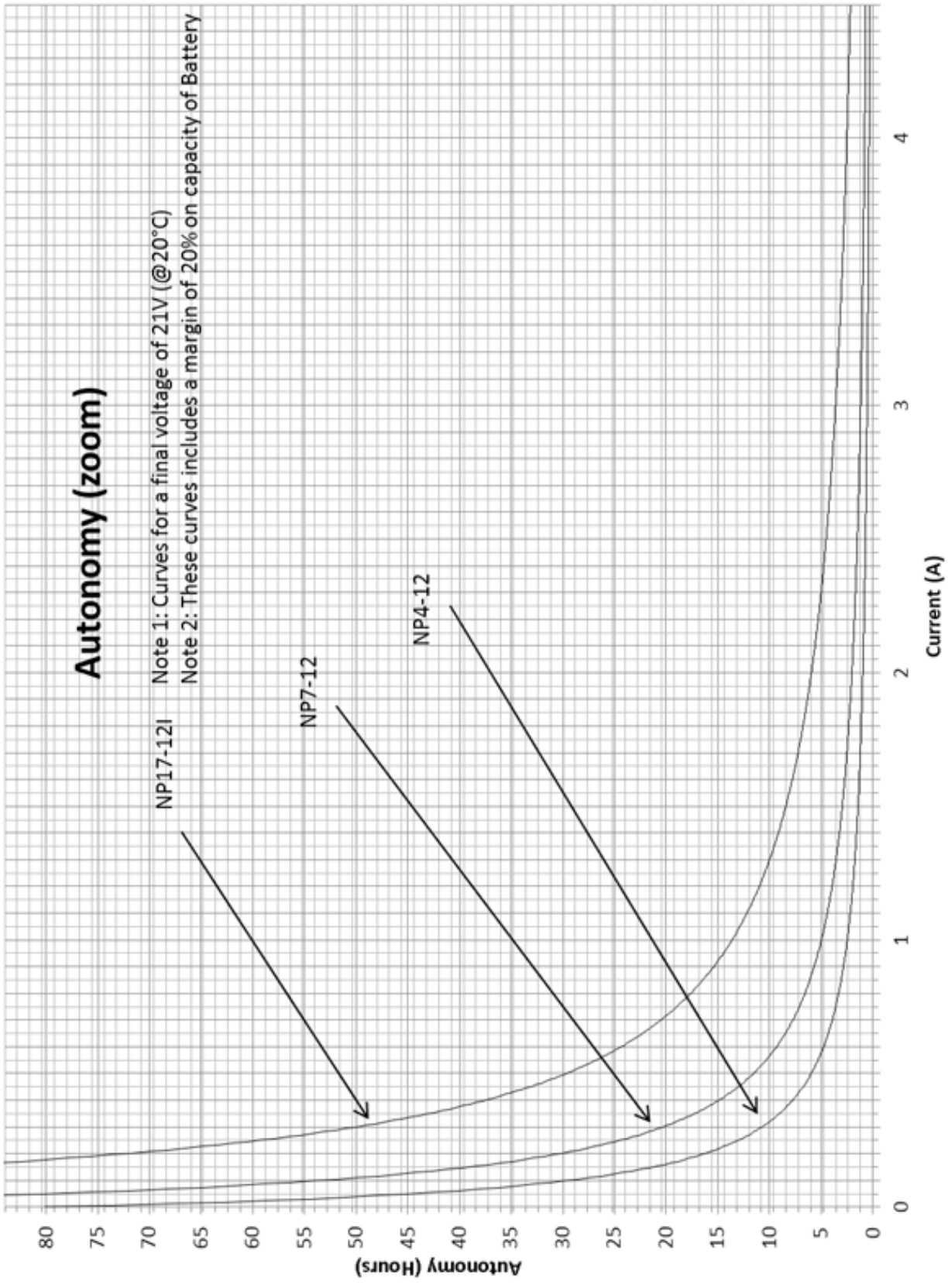

Eaton

Cooper Lighting and Safety Ltd
Wheatley Hall Road
Doncaster
South Yorkshire
DN2 4NB
United Kingdom
T: +44 (0) 1302 303 999
F: +44 (0) 1302 303 333
E: sales@cooperfire.com
www.cooperfire.com

Eaton

Cooper Industries Poland
ul. 17 Stycznia 45A02-146 Warszawa
e-mail: biuro@cooperindustries.com.pl
T: 22 320 50 10
W: www.cooperindustries.com.pl

Eaton Industries Belgium bvba-sprl

Locatie Groot-Bijgaarden
Industrialaan 1
1702 Groot-Bijgaarden
Belgium
T: +32 (0)2 719 8800
E: electricalbelux@eaton.com
www.eaton.be
www.coopersafety.be

Eaton

Cooper CSA srl
Via San Bovio, 3
20090 Segrate Italia
T: +39 02959501
F: +39 0295950598
www.coopercsa.it

Eaton

Cooper Pretrónica, Lda
Parque Industrial Serra das Minas
Avenida Irene Lisboa
Lote 19, Armazém C, Piso 2 2845-001
Rio de Mouro PORTUGAL
T: +351 219 198 50

Eaton

CEAG
Zentraler Kundendienst
Senator-Schwartz-Ring 26
D-59494 Soest
Deutschland
T: 02921 69-493
F: 0291 69-624
E: kundendienst@ceag.de

Eaton Industries (Netherlands) B.V.

Locatie Zaltbommel
Ambacht 6
5301 KW Zaltbommel
Netherlands
T: +31 (0)418 570 200
E: electricalnl@eaton.com
www.eaton.nl/electrical
www.coopersafety.nl

Eaton

Cooper Sécurité SAS
PEE II – Rue Beethoven – B.P. 10184
63204 RIOM Cedex – FRANCE
Technical service:
+33 (0)825 826 212 (0,15 € TTC/min)
Customers service:
+33 (0)820 867 867 (0,118 € TTC/min)
www.cooperfrance.com
www.eaton.com

Eaton

EMEA Headquarters
Route de la Longeraie 7
1110 Morges, Switzerland
Eaton.eu

© 2016 Eaton
All Rights Reserved
Publication No. ZNO1031200 A
September 2016

Changes to the products, to the information contained in this document, and to prices are reserved; so are errors and omissions. Only order confirmations and technical documentation by Eaton is binding. Photos and pictures also do not warrant a specific layout or functionality. Their use in whatever form is subject to prior approval by Eaton. The same applies to Trademarks (especially Eaton, Moeller, and Cutler-Hammer). The Terms and Conditions of Eaton apply, as referenced on Eaton Internet pages and Eaton order confirmations.

Eaton is a registered trademark.

All trademarks are property of their respective owners.